



सार भारती / PRASAR BHARATI

भारतीय लोक सेवा सारक / INDIA'S PUBLIC SERVICE BROADCASTER

अपर महा नदेशक(अ भ.) (द.)े का काया लय/ O/O. ADDL. DIRECTOR GENERAL (E)(SZ)

आकाशवाणी एवंदूरदश /न ALL INDIA RADIO & DOORDARSHAN

वामी शवानंदासालै,चे नई/ SWAMY SIVANANDA SALAI, CHENNAI – 600 005

(adgszpurchase@prasarbharati.gov.in / Tel. No. 044-25382155)

Kind Attention: All Prospective Bidders

Draft final specifications of upcoming Tenders as given under are uploaded to get feedback from industry and prospective bidders within 2 weeks i.e., on or before 03.12.2018 to adgszpurchase@gmail.com or on following address.

Room no.203, Deputy Director(Purchase),
O/o Addl.Director General(Engg.)(SZ), ALL
INDIA RADIO & DOORDARSHAN, Swamy
Sivananda Salai,Chennai-600005.

Specification No: No. ADG (E) (SZ)/PUR/NIT-/SRMST/2018-19/	Specifications for SETC of 150m SS Tower at HPT Mahabubnagar
---	---

SPECIFICATION FOR SUPPLY, ERECTION, TESTING AND COMMISSIONING OF 150m high SELF SUPPORTING STEEL TV TOWER AT HPT MAHBUBNAGAR.

1. INTRODUCTION

150 m high, lattice, all steel self-supporting tower, to support TV Transmitting Antenna and AIR FM antenna shall be erected at Doordarshan High Power Transmitter at Mahbubnagar, Telengana. The Tower shall be of self-supporting type having square lattice section base out of galvanized steel sections / structures of four legs. Antenna arrangements on tower are indicated in the suggestive Drawing No. JTT/IIT(M)/AIR/150-44/GA/01. Provision for both Band II and Band III Antenna apertures for FM and TV Service shall be made on tower.

After erection and painting of the tower, following antennae shall be mounted/ installed.

- i. Band IV UHF Antenna at tower top at 150 m level along with dual RF Feeder Cables.
- ii. AIR FM Panel Antenna in Band II aperture between 100m and 125m along with dual Feeder Cables.

Throughout the entire aperture of Band II & Band III, the outer to outer width of square cross section should be as per the drawings (including splices, nuts & bolts at joints)

- a. The Site is situated at Doordarshan High Power Transmitter Mahbubnagar, Telengana. The details of the site are
 - Longitude : 78°0'0" E
 - Latitude : 16° 44' 58" N
 - AMSL : 510 m.
- b. The Bidder shall quote for mounting of Band IV UHF TV Antenna System, dual Feeder Cables, AIR FM Antenna, Feeder Cables and related work / services as per details given in the subsequent paragraphs (BOQ). The bidder shall fabricate suitable interface to mount TV antenna at 150m level and FM antenna in Band II aperture starting from 100 to 125 m. Drawings of antenna and support structures will be provided.

2. SCOPE OF WORKS

The scope of the present tender includes the following as a turnkey job.

- a. Visit to the site by the bidder for collecting data and information on the date of pre-bid meeting (**Mandatory**).
- b. During the pre-bid meeting, prospective bidders will be shared with design drawings, report prepared by IIT, Chennai for erection of 150m self supporting TV tower, on request, after signing NDA(Non-Disclosure agreement). This will be sole property of Doordarshan and should not be shared in any form with any outsider as detailed in clause 6 of the specifications.
- c. The prospective bidders shall study the design provided by Doordarshan and point out shortfalls if any, for clarification, within 15 days. If no request/

- communication for clarifications is received from the bidders within the stipulated time, it will be presumed that, the design is acceptable and further bidders are responsible for the safety, reliability and soundness of the tower.
- d. Construction of Foundation for 150 m Self Supporting Steel Tower as per drawings.
 - e. Supply, Fabrication, galvanization, Erection of 150 m self supporting steel tower structure and Tower appurtenances / accessories including Antenna apertures for Band II & III, as per drawings. Internal ladders for climbing from ground to top of the tower, working platforms with railings, vertical Cable Racks / Trays as per drawings, cable clamps as per requirement and Horizontal Cable Tray between transmitter building to tower as per actual site condition. Actual lay-out for Horizontal Cable Tray as per the routing of feeder cables have to be prepared by the successful bidder and submitted for approval.
 - f. Supply Fabrication, installation of suitable interface to mount TV antenna at 150m level. Drawings of antenna support structures will be provided.
 - g. Installing lightening arrestor provided by the Department. Fixing of two numbers of lightning conductors to the lightening arrestors on the tower with suitable accessories and earthing them on the ground.
 - h. Earthing of four tower legs.
 - i. Supply and installation of Aviation Obstruction Lights (AOL) in the platforms. Electrical wiring and materials required for these AOLs shall be provided with suitable clamping.
 - j. Installation of Flashing Aircraft Warning Lighting System (AWLS) on the top of Band IV antenna. This light will be provided by the Department. Necessary electrical wiring and other materials required for installing this light shall be carried out by the successful bidder.
 - k. Provision of power sockets in the platforms, supply & installation of all necessary power supply cables, weather proof enclosures as given in Specification.
 - l. Painting of Tower Structure and allied parts as per specification.
 - m. Hauling up of UHF Antenna at 150 m level and 2 lengths of RF Feeder Cables as supplied by the Department.
 - n. Hauling up of FM panel Antenna and dual RF Feeder Cables supplied by the Department.
 - o. Cleaning of site by removing debris etc. and handing over the site.
 - p. Joint Inspection of the pending works with representatives of the firm & Doordarshan. successful Bidder shall carry out necessary works for correction as pointed out during Joint Inspection at his own cost.
 - q. Handing over the tower with photographs showing complete tower as well as each section of 20m length from base to top, horizontal cable tray and foundation processes starting from excavated area, steel layout and reinforcement etc. to leveled finished foundation.
 - r. Any other work necessary to complete the SETC work as a turnkey job.
 - s. Furnishing of third party certificate during supply of materials and completion of each phase of works.

3. GENERAL

- a. General terms and conditions of contract for SETC works including all the commercial aspects like Packing & Forwarding List, Insurance & Marine Risk etc., Payment Terms, Penalty / Compensation for delay, Damages & Liabilities, Time Period and Scope of work, Cancellation of Contract in Full or Part, Recovery of Security Deposit, Performance Guarantee, Unsatisfactory Workmanship, Damages incurred during Installation, Indian Electricity Rules, Defects, Recovery of Compensation, Ensuring Payment & Amenities, Compliance with State Labour Laws, Minimum Wages Act Compliance, Indemnifying Government against Patent Rights, Return of Surplus Material, Employment of Technical Staff & Employees, Release of Security Deposit, Safety Code etc. shall be followed by successful bidder as defined in Tender Document in totality.
- b. The specifications indicated herein are to guide the bidder about the requirements of Doordarshan. Successful Bidder shall be fully responsible for soundness of Supply, Erection of 150m Tower along with all other works listed in the scope of the Tender in Para 2 above including safety and reliability of complete turnkey Tower Construction Project.
- c. The successful bidder shall complete and include all minor / major items of appurtenances and accessories which may not have been enumerated in this specification and schedule but which are useful and necessary for completion of tower in all respect to this turnkey Project as per good engineering practices and no extra charges will be paid for providing and installing such minor / major items.
- d. The successful bidder shall make his own arrangements for power supply, water and the storage of materials and their safe custody at site for erection of tower.
- e. Prior approval of the purchaser, in writing, shall be obtained, if the successful bidder desires to sublet or assign any section of the work associated with the fabrication, supply, erection of tower, construction of foundation, mounting of Antennae etc. Such permission or approval shall not, however discharge the successful bidder from his liabilities in this contract or any part thereof.
- f. In the case of Consortium, the bidder shall submit bid on behalf of consortium along with Memorandum of Understanding (MOU), giving complete details of MOU on stamp paper duly notarised, clearly mentioning the roles and responsibilities. Doordarshan reserves the right to reject outright any bid unsupported by adequate documents / proof.
- g. (i) **The successful bidder shall make good all damage to the purchaser's building, property, equipment etc. how-so-ever arising from the erection of the tower, construction of foundation and in the course of such work and throughout the period during which the safety of tower is guaranteed.**
(ii) The successful bidder shall indemnify and hold harmless the purchaser against any claims in respect of damages to building, property situated nearby, not belonging to the purchaser, how-so-ever; arising from the erection of the tower, construction of foundation and in course of such work and throughout the period during which the safety of tower is guaranteed.

- (iii) The successful bidder shall indemnify and hold harmless the purchaser against claims in respect to injury / any mishap to any person how-so-ever arising out of the tower construction work and throughout the period during, the safety of the tower is guaranteed.
- h. The successful bidder shall be responsible for safe erection of the tower and other accessories etc. The bidder shall take all necessary safety measures and precautions during the SETC of Tower. Tower work shall be got done at site under the supervision of qualified representative of the firm.
- i. The successful bidder shall discharge all obligations under the Indian Workmen's Compensation Act any local, State Laws and Regulations in so far as it affects the workmen in his employment.
- j. The successful Bidder shall make his own arrangement for employing labour-skilled & unskilled and shall make his own arrangement for providing accommodation.
- k. The IS codes mentioned in this tender is suggestive. Relevant IS codes with latest amendments shall be followed and complied with.**
- l. The term "Successful bidder" mentioned in this tender document refers to the "Agency" executing the works.

4. ADDITIONAL CONDITIONS FOR TOWER WORKS

- a. Successful Bidder shall confirm after erection of tower that the **tilt, twist and rotation of the tower are within the specified limits, check & ensure verticality of the tower as per clause 9 of the specifications** and hand over the tower to the concerned Doordarshan/AIR authority after completion of acceptance test etc.
- b. There is space constraint at site and hence bidders should inspect the site of work(s), where the work is to be executed, before tendering and acquaint/satisfy fully themselves as the conditions in regard to accessibility of site, nature and extent of ground, working conditions including stacking of materials installation of tools and plants etc conditions effecting accommodation and movement of labour etc. required for the satisfactory execution of work.
- c. While executing erection of tower, all safety precautions shall be taken in accordance with relevant safety code for erection of structural steel work conforming to ICAO guidelines (IS: 7205) & as per the direction of the Installation officer.
- d. **Materials** to be procured by the successful bidder, as per the special conditions given in **Annexure I**. Due to restricted space available at site, successful bidder shall however make his own temporary arrangement for storage of materials and accommodation for labour etc.,
- e. The **erection** of the tower should be carried out strictly as per the guidelines for erection given in **Annexure II**. The successful bidder may, however adopt any other **standard procedure** for erection of the tower but he shall have to submit details of his proposed methods of erection for approval of the Zonal Office / Installation officer before commencing the work and get it approved from the Zonal Office / Installation officer.
- f. If at any time before the commencement or during the progress of the work, the method adopted or the appliances used appear to the Installation

officer to be inefficient or inappropriate for securing the quality of the work or the requisite progress, he shall bring it to the notice of the successful bidder who shall immediately comply with his instructions. Whereas failure of the Installation Officer to bring any shortcomings to the notice of the successful bidder does not relieve the latter of his obligations to achieve the quality of work and rate of progress required by the successful bidder. Any losses to the successful bidder on account of stoppage of work for above reasons have to be borne by the successful bidder.

- g. The erection of tower shall be carried out strictly as per the approved drawings for the tower and as per the directions of the Installation Officer.
- h. The tools and equipment required for the erection of the tower and temporary obstruction lights will not be supplied by Doordarshan. The successful bidder shall provide all the necessary erection tools and erection gang within the tender price and shall use such methods and appliances for the performance of all the operations connected with the work envisaged under the contract and shall ensure satisfactory quality of work and rate of progress.
- i. Wherever no mention has been made in the specifications, the work shall be carried out as per **relevant B.I.S standards** or as per the directions of the Installation officer given in writing based on sound engineering practice and local usage and that shall be final and binding on the successful bidder.
- j. During the installation of tower, arrangements will have to be made by the successful bidder for providing temporary obstruction lights as required under Aviation Regulation.
- k. The erection of towers should be carried out during normal working hours i.e., 8.00 am to 6.00 pm as laid down by factory rules / station authority.
- l. All electrical works, installation of aviation lights, lightning arrestor with earthing, power socket with cables and panels etc. and hauling up of DD and FM antennae shall be executed under the supervision of Installation Officer of Doordarshan. Payment will be made on the basis of certificate from Third party and Installation officer for satisfactory completion of work.

m. Protection of life & property and existing facilities :

- i. The successful bidder is fully responsible for taking all possible safety precautions during preparation, execution and actual performance of the works and for keeping the construction site in a reasonable safe condition. The successful bidder shall protect all life and property from damage or losses resulting from his construction operations and shall minimise the disturbance and inconvenience to the public.
- ii. In this connection the attention of the bidder is drawn to the safety measures and precautions including code of conduct while safely carrying out the work and also detailed engineering instructions enumerated in this tender which the bidder shall obtain in writing from Installation officer.
- iii. The successful bidder shall be solely liable for all expenses for and in respect of repairs and or damage occasioned by injury of or damage to such underground and above structures or other properties and undertake to indemnify and keep indemnified the Doordarshan from

and against all actions damages claims and demands what so ever either in law or in equity and all losses and damages and cost (inclusive between attorney and client) charges and expenses in connection therewith and or incidental thereof.

- iv. The current market value of any commodity lost as a result of any damage to the aforesaid existing facilities shall be paid by the bidder together with such additional sums necessary to liquidate the personal or property damages resulting there from.

n. Indemnities :

The successful bidder shall at all times hold Doordarshan harmless and indemnify from all actions, suits proceedings , works, cost, damages, charges claims and demands of every nature and descriptions brought or procured against the Doordarshan its officers and employees and forthwith upon demand and without protest or demur to pay to the Doordarshan any and all losses and damages and cost (inclusive between attorney and client) and all costs incurred in endorsing this or any other indemnify or security which the Doordarshan may now or at any time have relative to the work or the successful bidder's obligations or in protecting or endorsing its right in any suit or other legal proceedings , charges and expenses and liabilities resulting from or incidental or in connection with injury, decease or disablement to or death of any person(s) including employee(s) of the successful bidder or damage to resulting from or arising out of our in any way connected with or incidental to the operations caused by the successful bidder documents. In additions, the successful bidder shall reimburse the Doordarshan or pay to Doordarshan forthwith on demand without protest or demur all cost, charges and expenses and losses and damages otherwise incurred by it in consequence of any claims, demands and actions which may be brought against the Doordarshan arising out of or incidental contract.

- o. The successful bidder's rate shall among other things, include the cost of working in multiple shifts round the clock if necessary, including Gazetted holidays, if necessary and the cost of mobilization of all types of resources, T&P lighting etc. with advance information to IO.

p. Size of the material :

- i. Where the successful bidder is required to provide materials of certain sizes or weights which may have become out of market due to change over to metric standards, **substitute conforming to the nearest better equivalents** as approved by the Installation officer shall be used. No claim of extra payments shall be entertained on this account.
- ii. **Large size details shall take precedence over a small size drawings.** The special dimensions in the specifications or schedule of quantities or instructions of the Installation officer shall supersede. All dimensions shall be verified at site and any discrepancy shall be reported to the Installation Officer. The bidder at all stages will make necessary amendments at his own cost, should the work be found to

- be not consistent with the requirements of all drawings, even though it may have been prime facie approved by the Installation officer.
- q. The levels of measurements and other information concerning the existing site as shown in the drawings or as described are supposed to be **correct but the successful bidder shall verify them for himself and no extra claim whatsoever shall be entertained on account of the errors or omissions in such matters** or on account of the descriptions turning out to be different from what was expected.
- r. Arrangement for tools and water :
- i. The successful bidder shall bear the cost of all tools, plants equipment and rigs etc. required for the work including their transportation to site and removal from the site after completion of the work and nothing extra will be paid on this account.
 - ii. **The water shall be tested by the bidder with regards to its suitability for use in RCC works and nothing extra shall be paid on.**
- s. **Co-ordination with other agencies :**
- i. successful Bidder shall extend necessary coordination and cooperation with the other agencies like State electricity authorities, local administration, etc. required for smooth execution of the project.
 - ii. The successful bidder shall give all necessary notices, to the Municipality, Police, Mining and other authorities that may be required by law and obtain all requisite licenses for temporary obstructions and enclosures and pay all fines, taxes and charges which may be leviable on account of this.
- t. The successful bidder shall make his own arrangement for temporary electric connection at works if required, and make necessary payment for it directly to the Department concerned. The wiring done by the successful bidder shall conform to the electrical regulation of statutory bodies and be consistent with the safety requirement of the site. The Installation officer's decision regarding the safety aspect shall be final and binding on the successful bidder.
- u. The successful bidder shall leave such recesses, holes, openings etc. as may be required for the electrical and technical cabling of Doordarshan etc. No extra payment will be made to on this account.
- v. The successful bidder shall provide adequate lighting arrangements as approved by the Installation officer for carrying out the works during night times when required and also provide all other facilities for the labour employed to carry out the works without any extra charge. Under direction by Installation Officer, necessary lighting shall also be provided by the successful bidder for yard lighting as well as to cover the entire site required for safety and security reasons, without any extra charges.
- w. The successful bidder shall keep the site neat and clean during the execution of work as far as possible. Any excess earth and debris shall be disposed as per instructions of Installation Officer and the successful bidder shall be responsible for any objections of Municipal or other local bodies for occupying roadway and nuisance to others including payment of penalties thereon.
- x. **Within 30 days of the date of the work order the successful bidder shall submit a complete detailed works programme(bar chart/pert chart) including programme for procurement and supply of materials etc and**

the same shall be approved by Zonal Office. Such submissions shall be made in four copies. At any time, if it is found that actual progress in any item is lagging behind by more than a week from the initial projection, bidder will have to submit a new programme, indicating how he intends to make up the lost time.

- y. The successful bidder shall make adequate fire fighting arrangements at no extra cost and shall be fully responsible for any fire consequences at the work site.
- z. The successful bidder shall provide all necessary covering and boards and protect the excavated area from inclement weather. Every precaution shall be taken against slips, falls or collapse of the earth, clay and other materials during the excavation. In the event of any earth slips, the successful bidder shall remove the surplus materials arising out of these at his own cost and shall make good the space caused by the slip, ups and falls which may be outside the dimensions of the work ordered.
- aa. The successful bidder shall study all the existing services on site and shall take all necessary precautions to keep them in working condition, during constructing period. It will be the total responsibility of the successful bidder to ensure against any type of damage to the existing services etc., failing which successful bidder will be liable to all consequential claims arising thereon. Successful Bidder shall take special care against any damage to the existing TV transmitter and the associated electrical and TV cables
- bb. The successful bidder shall possess, procure and keep adequate centering, shuttering T&P hoists for materials and supervision, tower cranes, trucks, mixers, vibrators, curing arrangements, welding sets and all other essential items commensurate with demand of project completion, and demur.
- cc. A procedure for routine testing of all materials (concrete, rebar, and structural steel) and works shall be laid out as instructed by the Installation Officer/ Zonal office. In general all consumable materials have to be specifically approved by Installation Officer. **Any test certificates of manufacturer etc. demanded before approval shall be furnished by the bidder.** The tests shall be carried out at a laboratory approved by the Installation officer/ Zonal office. The successful bidder shall ensure and certify the calibration of the equipment so installed and shall maintain the same in working order throughout the period of foundation work. The successful bidder shall also provide necessary trained staff for carrying out such tests and using such equipment. All tests shall be carried out under the supervision of Installation officer. In case sample of materials are to be tested away from site cost of preparing the samples, packing and carrying to and from to laboratory shall be borne by the bidder but testing charges if any shall be reimbursed by the Department as stipulated in **Annexure I, point no.4.**

5. SPECIAL CONDITIONS

- a. The successful bidder shall provide 3 numbers of walkie talkie instrument or mobile sets to the site supervising staff for co ordination and communication of instructions to site supervisor / staff / labour involved in

- construction of tower. If this is not feasible, any other efficient facility of communication shall be ensured at site.
- b. Successful Bidder shall give the Installation Officer on the **5th day of each month**, 4 hard copies and one soft copy (on CD) of progress report of the work done during the previous month. Such progress report will include the project progress summary, work progress (planned versus actual) in Critical path method (CPM) chart, milestone status, financial progress status, manpower deployment status, important materials consumed, materials at site at the beginning of the month of report, materials consumed during the month and the balance quantities at the end of month and photographs of important activities as well as showing progress of work. For unjustified delay in submission of the progress report, compensation @2500 (Rupees Two thousand five hundred only) per instance of delay will be recovered from the dues of the bidder subject to maximum of Rs.1,00,000/- during the entire project.
 - c. Existing drains, pipes, cables, overhead wires, sewer lines, water lines and similar services, if any encountered in the course of the execution of work shall be protected against the damage by the successful bidder at his own expense. The successful bidder shall not store materials or otherwise occupy any part of the site in a manner likely to hinder the operation of such services. In case temporary supporting /shifting of such services is required to facilitate the work, the same shall be done by the successful bidder at no extra cost.
 - d. In case the existing services are to be shifted permanently, alternate / diversion of service lines has to be laid by the successful bidder, before dismantling the existing services, so that there is no interruption in use of existing services. The bidder has to plan the alternate suitable route for diversion / shifting of existing lines and get the same approved from the Installation Officer before starting shifting of services. **Nothing extra shall be paid except the payment of dismantling and laying of new service lines as per the rates in the bid.**
 - e. All materials and fittings brought by the successful bidder to the site for use shall conform to the samples approved by the Installation Officer which shall be preserved till the completion of the work. The particular make/ brand of material specified in Schedule of Quantity, only shall be used with the approval of Installation Officer. Wherever brand / quality of material are not specified in the item of work / Schedule of Quantity , the successful bidder shall submit the samples as per list of preferred makes given in the tender document / particular specifications for approval of Installation Officer. For all other items, materials and fittings of ISI Marked shall be used with the approval of Installation Officer. Wherever ISI Marked material fittings are not available, the successful bidder shall submit sample of materials / fittings manufactured by reputed firms conforming to relevant specifications or IS codes and use the same after getting the approval of Installation Officer. To avoid delay, successful bidder should submit samples as stated above well in advance so as to give timely orders for procurement. If any material, even though approved by Installation Officer is found defective or not

conforming to specifications shall be replaced / removed by the successful bidder at his own risk and cost.

- f. The successful bidder shall ensure quality construction in a planned and time bound manner. Any sub-standard material / work beyond set-out tolerance limit shall be summarily rejected by the Installation Officer and successful bidder shall be bound to replace / remove such sub-standard / defective work immediately.

6. PATENT & COPY RIGHT

The successful Bidder shall hold the purchaser and his employees safe, harmless and immune from any liability that may arise out of infringements of patents and copyright associated with fabrication, erection of Tower construction work and its accessories.

The successful bidder shall keep all technical information and drawings provided along with the tender in confidence and to take the same degree of care as with respect to his own proprietary data to prevent the disclosure to third parties.

Technical information and drawings provided by Doordarshan under this tender shall not be used for any other purpose, except the purpose set out under this tender.

7. ELIGIBILITY CRITERIA

Eligibility Criteria is aimed at checking bidders Capability, Technical proficiency, financial soundness, Mobilization of tools and plant, Mobilization of man power and timely completion. Bidders may please note that all the above mentioned parameters would be considered while evaluating the bids

- a. **“Work” referred below in this clause means, foundation for tower, supply, fabrication, erection of structural steel and successful completion/commissioning of tower.**
- b. **“Tower” means free standing / self supporting steel frame work to support Antenna systems.**
- c. Intending bidders are eligible to submit the bid provided they have definite proof/documents issued by the appropriate authority, which shall be to the satisfaction of the competent authority, of having satisfactorily completed works of magnitude specified below.

In the past twenty years, as on last day of the month, previous to the month of invitation of this tender, the bidder should have carried out,

- one work of height not less than 120m

or

- two works of height not less than 90m

or

- three works of height not less than 75m.

- d. The bidders shall enclose Work orders of Tower Works, Completion Certificates in support of experience and provide Clients' Addresses,

Telephone Numbers, Fax Numbers, e-mail addresses etc. in the following format.

Order No. with date, reference	Tower Type and height of tower	Quantity & value in rupees	Name of the organization with full postal address for whom tower was erected.	Details of performance certificates of the contract.
(1)	(2)	(3)	(4)	(5)

- e. The bidder shall furnish the following details also in respect of above work orders

Order No. with date, reference	Tower Type and height of tower	Stipulated date of commencement	Actual date of commencement	Stipulated date of completion	Actual date of completion	Penalty, if any
1	2	3	4	5	6	7

- f. Bank Solvency Certificate to the amount of not less than Rs.500 lakhs shall be enclosed
- g. The bidder should have had average annual financial turn over(gross) of not less than Rs.500 lakhs during the immediate last three consecutive financial years duly audited by Chartered Accountant
- h. The bidder should not have incurred any loss in more than two years during the immediate last 5 consecutive financial years ending 31st March 2018 duly certified by Chartered Accountant
- i. If the bidder is an individual, the bid shall be signed by him above his full type written name and current address
- j. If the bidder is a proprietary firm, the bid shall be signed by the proprietor above his full type written name and the full name of his firm with current address.
- k. If the bidder is a firm in partnership, the bid shall be signed by all partners of the firm above their full type written names and current addresses, or, alternatively ,by a partner holding power of attorney .for the firm/s. In later case a certified copy of the power of attorney should accompany the bid. In both cases a certified copy of the partnership deed and current address of all partners of the firm should accompany the bid.
- l. In case of MOU with other firm/s, full details like experience of the firm, roles and responsibilities, liabilities etc., shall be attached with the bid. The MOU

shall be on a stamp paper duly notarised. Doordarshan reserves the right to reject outright any bid unsupported by adequate documents / proof.

- m. The bidder should have experienced technical staff on tower works as detailed below.

SI No.	Miniumum Qualification of Technical Representative	Discipline	Designaion(Principal Technical/ Technical Representative)	Minimum Experience	Number	Rate at which recovery shall be made from bidder in the event of not fulfilling clause 7m
1.	Graduate Engineer	Civil	Principal Technical Representative	5 Years	1	Rs.25,000 per month
2.	Project Engineer OR Diploma Engineer	Civil	Project/Site Engineer And Engineer	2 years 5 Years	2 2	Rs.15,000 per month each
3.	Graduate Engineer OR Diploma Engineer	Electrical	Principal Technical Representative	2 years 5 Years	1 1	Rs.15,000 per month each

Assistant Engineers retired from Government service with qualification of Diploma in Engineering will be treated at par with Graduate engineers.

- n. Doordarshan reserves the right to get performance feedback of the towers erected by the bidder from any of the end user of such towers named by the bidder.

8. DOCUMENTS AND DETAILS TO BE SUBMITTED WITH THE TECHNICAL BID

- a. Details of reinforcement steel to be used in foundation (make).
- b. Details of Anchor bolts, Rock Anchors proposed to be supplied (make/type).
- c. Details of steel and fasteners to be used for structure (make/type).
- d. Details of aviation lights to be provided in platforms (make, type, model, battery backup, sun switch etc) with catalogues.
- e. Details of past experience in the prescribed format given in Page 7d and 7e. and copies of work orders and completion certificates from the clients.
- f. Bank Solvency Certificate to the amount of not less than Rs.500 lakhs.
- g. The bidder should have had average annual financial turn over (gross) of not less than Rs.500 lakhs during the immediate last three consecutive financial years duly audited by Chartered Accountant. Relevant documents may be enclosed.
- h. The bidder should not have incurred any loss in more than two years during the immediate last 5 consecutive financial years ending 31st March 2018. Audited financial statements duly certified by Chartered Accountant and relevant documents may be enclosed.
- i. All pages of tender shall be numbered serially. All pages of tender document, technical specifications, Bill of quantity, subsequent amendments shall be signed by the bidder with seal.

- j. Para by Para Compliance Statement in the format as given below, for all the paras of specification, shall be attached with the offer duly signed by the bidder on each page of the Compliance Statement.

Para No. of DD specification	DD specification details	Page No. / Annexure no. of the technical bid where this information is provided	Compliance or deviation	Remarks if any
(1)	(2)	(3)	(4)	(5)

- k. If it is not possible to provide full information in the prescribed format against any given specification, the additional information may be provided in Annexures and the Annexure No. may be written in the corresponding row of Column-3.
- l. **It is mandatory that the bidders shall attend the Pre Bid Meeting at site. The design drawings will be shared on request with Non disclosure agreement during Pre Bid Meeting.**

9. VERTICALITY OF TOWER

- The Tower shall be vertical after erection and no straining shall be permitted to achieve this.
- The erection tolerance of verticality shall be within 25mm every 9100mm, subject to overall verticality of Tower within 50mm after erection of full height of tower and stage wise corrective action shall be taken to achieve the above.
- The successful Bidder will have to satisfy Doordarshan that verticality of Tower is maintained within 50 mm after erecting full height of Tower at site on two adjacent faces.
- The verticality tests shall be got carried out at the cost of the bidder, using Total Station, from any Govt. Engineering college / Institute in presence of DD Representative and the authority for third party certification. Report shall be submitted in triplicate.**

10. DATE OF COMPLETION

The complete Turnkey Tower Project shall be completed as early as possible, but not later than **15 months from date of issue of work order**.

S.No	Description of mile Stone (Physical)	Time allowed in Months	Amount to be withheld in case of non achievement of mile stone.
1.	Foundation (Including Excavation and RCC work,curing)	Four months	In the event of non-achieving the necessary progress as assessed from the running payments, 1% of the tendered value of the
2.	150 m Steel structure	Eight Months	

3.	RF cables hoisting, Antenna erection, AOL Installation Vertical cable Tray work and all other work assigned in tender	Three Months	work will be withheld for failure of each milestone.
----	---	--------------	--

11. TECHNICAL SPECIFICATION FOR FOUNDATION WORK

a. Foundation :

- i. The foundation works shall be carried out according to **drawing Nos.JTT/IIT-M/DEC/16/05/DD/272/FDN(2 Nos)**. Foundation shall be constructed as per approved drawing and design of foundation and in accordance with IS:456 (with latest amendments) and other applicable provisions of BIS Code and Practices.
- ii. The orientation of the Tower base is to be got confirmed from Doordarshan Installation Officer before taking up the foundation work at site.

b. Material :

- i. All material used in production of concrete including all ad mixture shall be in accordance with IS 456 (with latest amendments). The cement concrete used for foundation RCC & PCC shall be of grade M-25 & M-10 respectively and as per IS 10262 with latest amendments. For foundation, Ready Mix Concrete(RMC)only is permitted. Necessary test certificate for the cement used to be produced. Design mix shall be done by any Government Institution.
- ii. The Portland Cement of 43 grade to be used in concrete shall conform to IS:8112 (with latest amendments).
- iii. Width of PCC is 500mm on each side. **Depth of foundation pits to be excavated below existing ground level is minimum 2.2m.**
- iv. Grout mix shall be cement based and of M 25 grade complying to IS 456.
- v. Concrete aggregates shall conform to IS:383 (with latest amendments).
- vi. All Properties of concrete regarding its strength under compression, tension, shear punching and bond etc. as well as workmanship will confirm to IS:456 (with latest amendments).
- vii. The water used for mixing the concrete shall be fresh, clean and free from oil, acids and alkalies, organic materials or other deleterious substances. Water shall be tested for potability and hardness.
- viii. The type of cement, aggregate and concrete used shall be the best grade. The foundation shall be watered and cured for at least 21 days before the erection of the Tower. The erection of tower shall be commenced only after the foundations are thoroughly cured. Measurements of levels of all tower footings will be taken in presence of DD Officials.
- ix. Reinforcement bars shall conform to IS:432 (with latest amendments) for Mild Steel Bars and hard drawn steel wires to IS:1139 (with latest amendments) and IS:1786 (with latest amendments) for deformed and cold twisted (TMT) bars respectively. Overlapping of reinforcement bars shall be done as per drawings and standards.

- x. All reinforcement bars shall be clean and free from loose mill scales, dust, rust, coats of paints, oil or other coating, which may destroy or reduce bond.
- xi. The successful bidder shall supply, fabricate and place reinforcement to shapes and dimensions as indicated or as required to carry out the intent of drawing and specifications.
- xii. Rock Anchor rods of grade 415 MPa conforming to relevant IS code shall be provided as per drawing. It is preferable to use Single anchor rod for full length of the foundation.
Only in case of non availability of single anchor rod for the full length of the foundation, suitable tested couplers with necessary test certificates shall be used for extending the length of anchor rods. In such case, strength of the rod with couplers shall be tested in approved lab and report submitted.
- xiii. Material used for Anchor bolts and nuts shall be of Fe 415 grade. 12 nos of anchor bolts with a minimum length of 1800 mm in concrete and overall length of 2200mm shall be provided in each leg. Exposed portion of anchor bolts and 300 mm below concrete shall be galvanized as per relevant IS code. Test certificate of anchor bolts and nuts shall be produced.
- xiv. Anchor bolts setting template shall be made interconnecting the four locations of footing.
- xv. The Bidder shall also submit still photographs of excavated foundation area and its various stages of foundation work.

c. Workmanship :

- i. All workmanship for foundation work shall be in accordance with Specifications, approved drawings and IS:456 (with latest amendments),
- ii. While excavating the pits, excavation shall be adequately supported or formed to ensure stability of the sides and prevent any damage to the surrounding ground or structures.
- iii. Excavated material suitable for re-use as backfill shall be stored within the site working area.
- iv. The Bidder shall not permit water accumulation in excavated pit.
- v. The Bidder shall carry out concrete trial mix using representative materials under full scale condition as per IS:10262 with latest amendments, subject to approval of Installation Officer. The testing shall be carried out accordance with IS:456 (with latest amendments), Minimum three test cubes shall be tested for every batch.
- vi. The Bidder shall carry out slump or other Workability Tests as required during concreting of work, in order to relate the degree of workability of the mix to the values obtained during the trial mix.
- vii. All frameworks shall be accurately constructed to produce the correct foundation shape and shall be sufficiently strong to withstand pressure arising from concrete during placement and compaction.
- viii. Reinforcement Bar shall be bent and fixed in accordance with procedure specified in IS:2502 (with latest amendments). The high strength deformed steel bars should not be re-bent, straightened. All

the reinforcement should be placed and maintained in the position as shown in the drawing by providing proper block, spacers and supporting bar.

- ix. The concrete shall be placed in layer maintaining proper cover of reinforcement, which shall be compacted by vibrators.
- x. The curing & protection shall start after setting time of concrete and adequate protection shall be ensured.
- xi. Backfilling shall be compacted in 300mm layers to achieve sufficient compaction.
- xii. The Bidder shall clear the site from all surplus soil and other materials before handing over the Tower to DD.
- xiii. Inspection and Testing of concrete work shall be in accordance to provisions of IS:456 (with latest amendments).
- xiv. In case of rock anchorage type foundation, workmanship & other requirements shall be in accordance with IS:10270 (with latest amendments).

12. TECHNICAL SPECIFICATIONS FOR STEEL TOWER

a. Tower Steel Section :

- i. All tower members shall be made out of structural steel conforming to IS-2062, amended to date, and of Class A or Class BR with minimum yield strength of 250 MPa.
- ii. Steel shall be procured exclusively from the main producers like SAIL / IISCO / TISCO / RINL/JINDAL.
- iii. In case certain steel sections are not available in the market in the designed thickness, the next higher thickness available should be used.
- iv. The material shall be of tested quality, recent manufacture & free from scales, slag intrusions, pitting, flake, rusts etc.
- v. The successful bidder shall arrange for procurement of Zinc required for galvanizing the structure by him. The Zinc required for galvanizing shall be of quality Zn 99.99 purity and shall conform to IS 209 with latest amendments.

b. Fasteners (Bolts, nuts and washers) :

- i. The Tower members and other components of structure shall be connected / assembled by means of nuts and bolts with locking nuts. In case of riveting and welding is employed for connection of Tower members, same shall be got approved from Purchaser prior to its use. Necessary approval must be attached with the Inspection Note by the Supplier. **There shall be 2 numbers of bolts of M16 in all redundant members.**
- ii. The quality of steel used for nuts, bolts, washers etc. should conform to mechanical properties as per IS 1367/79 (with latest amendments) and dimension to IS:6639(with latest amendments). The heads being forged out of solid, truly concentric and square with the shank and shall be perfectly straight. All bolts shall have hexagonal heads and hexagonal nuts. The bolts shall be threaded with standard threads to

take the full depth of the nut. All nuts shall fit tight to the bolts. No appreciable fillet shall exist at the point where shank of the bolt connects to the head. Lock nuts shall be provided to all bolts and nuts. The successful bidder shall include sufficient spare bolts and nuts to compensate for loss / damage in the field during erection. The bolts and matching nuts shall be of 16/20/24mm diameter as per design requirement and of minimum property class 8.8 Grade as specified in IS:1367 part 3-1991/IS:6639 .

- iii. All bolts shall be threaded to take the full depth of the nuts and to permit firm gripping of the members, but not further. It shall be ensured that the threaded portion of each bolt protrudes not less than 3mm and not more than 8mm when fully tightened. All nuts shall fit and tight to the point, where the shank of the bolt connects to the head.
- iv. Flat and tapered washers shall be provided wherever necessary, spring washers shall be provided for insertion under all nuts. These washers shall be steel electro galvanized, positive lock type and 3.5mm in thickness for 16mm dia bolts and 4.5mm for 24mm bolts.
- v. Nuts shall be double chamfered as per the requirement of IS:1363 (with latest amendments). It should be ensured by the manufacturer that nuts should not be over tapped beyond 0.4mm over size on effective diameter for size upto M16.
- vi. Bolts upto M16 and having length upto 10 times the diameter of the bolts should be manufactured by cold forging and thread rolling process to obtain good & reliable mechanical properties and effective dimensional control. For the bolts the test certificate should contain mechanical properties, manufacturing process and chemical composition
- vii. The shear, bearing & tensile strength shall be in accordance with IS:800 (with latest amendments). The fasteners shall be procured from reputed manufacturers such as UNBRACO, TVS, NEXO, USHA etc.
- viii. All the bolts and nuts shall be galvanized by high temperature hot-dip galvanizing at temperature at 530°C in accordance with IS:1367 & IS:5358 (with latest amendments). The galvanizing coating should be uniform and its value should be between 85 to 115 micron to be checked on random sample basis on the threaded portion as well. The washers, spring washers shall be hot-dip galvanized as per Grade 4 IS:1573 (with latest amendments). The galvanized coating shall be checked in NABL accredited lab and necessary test certificate shall be submitted.

c. Fabrication :

- i. The work shall be carried out in a thoroughly reliable manner using good engineering practices and workmanship in order to ensure satisfactory assembly and erection, inter changeability of similar members, accuracy of dimensions, position and alignment of holes etc.
- ii. The fabrication of various components of the tower shall be in accordance with the approved drawings.

- iii. The fabrication of Tower components shall confirm to IS:800 (with latest amendments).
- iv. All steel sections shall be fabricated as per the approved drawings. Members not meeting the requirement of design and drawing shall not be allowed to be used for erection and shall be replaced by the Bidder free of cost.
- v. All steel members shall be reasonably straight and if required are fully straightened and trued by pressure and not by hammering.
- vi. **Gas cutting, shearing, sawing, modification of holes, welding etc. is not permitted for finished members at site.**
- vii. Stress relieving of the base plate as per relevant standards and code is to be carried out.

d. Drilling and Punching :

- i. Holes for bolts shall be drilled or punched with jig, but drilled holes shall be preferred. Punching may be adopted for thickness up to 16mm. Tolerance regarding punched holes are as follows :
 - 1) Holes must be perfectly circular and no tolerance in this respect will be permissible.
- ii. The maximum allowable difference in diameter of the holes on the two sides of plates or angles shall be 0.8mm
- iii. Holes on both side of the bend line in a bent member shall be drilled after bending.
- iv. The mild steel section up to 75 x 75 x 6 may be bent by cold process up to bend angle 10° and all other angle sections and bend angles shall be bent by hot process.
- v. **Unless specified in drawings, the formation of bends by the “Cut & Weld” method is not permitted without prior approval of DD.**
- vi. No angle member shall have two leg flanges brought together by closing the angle.

e. Welding :

- i. Welding if any shall be carried out in accordance with IS:816, IS:1024 and IS:9595 (with latest amendments) as appropriate.
- ii. Butt welding shall be carried out either by submerged arc or shielded arc welding.
- iii. Pre-heating and post heating shall be employed as may be necessary for welding members.
- iv. For welding of any particular type of joint, welder shall give documents acceptable to DD of having satisfactorily completed appropriate tests as described in relevant codes.

f. Tolerance :

- i. Fabrication tolerances shall not exceed those specified in IS : 7215 as applicable to Group B Structures.
- ii. Deviation from straightness of any member shall not exceed 0.001L subject to maximum of 10mm, where L is the unbraced length in meter.
- iii. Tolerance of hole to adjacent hole distance shall be within ± 1 mm.
- iv. Tolerance on the overall length of a member shall be within $\pm 2\%$.

g. Galvanizing :

- i. All steel tower members shall be hot dip galvanized after fabrication is completed. The galvanization of the tower members shall conform to IS:2629 and IS:4759 (with latest amendments).
- ii. The thickness of hot dip galvanizing shall be generally 85 microns (equivalent to 610g/m² of Zinc Coating) in accordance with IS:4759 (with latest amendments).
- iii. All galvanized members shall withstand test as per IS:2633& IS:3203 (with latest amendments).
- iv. All material prior to galvanizing shall be free from scale, oil, grease or any substance which may adversely affect the quality of galvanizing.
- v. Excessively thick or brittle coating due to high levels of silicon or phosphorus in steel which may result in an increased risk of coating damage and / or other features that make the final product non-fit-for-use, shall be rejected.
- vi. The preparation for galvanizing and galvanizing itself shall not adversely affect the mechanical properties of the coated materials.
- vii. All fasteners shall be galvanized in accordance with IS:1367 (with latest amendments) and IS:5358 (with latest amendments).
- viii. Spring washers shall be electro galvanized as per Grade 4 of IS:1573 (with latest amendments).

13. INSPECTION AND TESTS

a. Foundation :

- i. **Level Measurements** :The levels at the four corners of the tower footing should be maintained at the same level.
- ii. **Test for Strength of Foundation:** The concrete used in the foundation should be designed as per IS:10262. Along with the foundation, cubes should be cast, which can be tested on 7 days and 28 days to get the strength of the concrete used in the tower foundation. CC cubes and reinforcement used in the foundation must also be tested in a National Testing Laboratory /IIT /NIT/ Reputed Government institutions. Also, after complete curing of foundation, the strength of the footing may also be ascertained by conducting non-destructive test using Ultra Sonic Pulse Velocity Method.
- iii. Reinforcement bars, anchor rods shall be tested as per relevant IS code in NABL accredited lab. Strength of the anchor rods with coupling / joint shall also be tested. It is preferable to use Single anchor rod for full length. Suitable couplers may be used for extending the length of anchor rods, only in case of non availability of single anchor rod for the full length. In such case, strength of the rod with coupler shall be tested in NABL accredited lab and report submitted.
- iv. If desired result is not achieved in any of the above tests, the material / work shall be replaced / redone.

b. Structural Steel :

- i. Original copies of the Manufacturers Test Certificates of steel should be sent to DD (Doordarshan). Steel collected should be properly

stacked at Bidder's works to avoid corrosion and placed for physical verification by DD.

- ii. The successful bidder shall offer all assistance in regard to DD's inspection and proper care shall be taken so that steel collected for DD's work is not mixed up with the steel for other Agencies works.
- iii. Successful bidder shall arrange to test samples of fabricated and / or raw steel for each type, selected at random by the installation officer, at any Govt. approved Laboratory.

Test should be made in accordance with provisions of concerned IS (latest). The various test procedures to be performed are as follows :

- 1) Material Specification as per IS-2062 (Grade – A/ BR) and tolerances as per IS-1852.
- 2) Sampling shall be as per IS-2500.
- 3) Physical Properties.
 - a) Manufacturer's Test Certificate.
 - b) Actual Test Certificate from Laboratory.
- 4) Dimensional and visual inspection shall be in accordance to IS-808 and IS-1852.
- 5) Chemical Property in accordance to IS-2062.

c. Fasteners :

- i. Manufacturer's routine Test Certificates for bolts, nuts, washers etc. as laid down in relevant IS Code shall be submitted by the successful bidder at the time of inspection. In addition, minimum ten numbers of Random Sample Tests for bolts and nuts for Proto-Type strength Tests shall be performed by the successful bidder / agency in Government approved Test Laboratory.
- ii. The various test procedures to be performed are as follows :
 - 1) Materials Specification IS-6639 / IS-1363 / IS-1367.
 - 2) Sampling shall be as per IS-1367.
 - 3) Visual Inspection.
 - 4) Dimensional Checking for Bolts & Nuts in accordance to IS-6639 and IS : 1363 respectively.
 - 5) Mechanical and strength properties of Test Nuts & Bolts – To property class minimum 8.8 Grade as per IS :1367/ IS : 6639.
 - 6) Galvanizing Test in accordance to IS :1367.

d. Galvanizing :

- i. The successful bidder shall prepare a detailed galvanizing procedure including Flow Chart with control parameters and all plant standards as required above and submit to DD for approval as part of Quality Assurance Plan.
- ii. The various test procedures to be performed on the finished galvanized materials
 - 1) Visual Inspection in accordance to IS-2629.
 - 2) Uniformity of coating as per IS-2633
 - 3) Magnetic Gauge Test
 - 4) Stripping Test
 - 5) Adhesion of coating as per IS-2629.

- iii. Successful bidder shall perform routine test atleast for three samples from each batch of production and record the result in separate Register. DD's Inspection Officer will be present at the time of Test. Successful bidder should submit regularly the result of all the tests performed to the Inspection Officer of DD.
- iv. All Standard Tests, including Quality Control Tests, in accordance with appropriate Indian BIS Standard shall be carried out unless otherwise specified herein,
- v. The successful bidder shall submit all the Test Certificates during inspection.
- e. **In addition to the above, the following points regarding Inspection shall be followed.**
 - i. Successful bidder shall keep DD informed in advance about time of supply or the schedule of fabrication of various parts, so that it can be inspected.
 - ii. The acceptance of any part or items shall in no way relieve the successful bidder of any part of his responsibility for meeting the overall requirement of the Specifications.
 - iii. Installation Officer / representative of DD shall have free access at all reasonable times to those parts of successful bidder's Works, where fabrication work is carried out for satisfying him that fabrication is being done in accordance with the Specifications,
 - iv. Inspection shall be made at the Works of successful bidder prior to dispatch.
 - v. The correct grade and quality of steel shall be used by the successful bidder. The successful bidder shall make available the manufacturer's Test Certificate to substantiate the same at the time of Inspection.
 - vi. Any member of the structure found not to comply with the approved drawings, shall be rejected. No member once rejected should be resubmitted for inspection except in case, where Inspection Officer considers that the defect can be rectified.
 - vii. Welded members / connections, if any, shall be subject to a non-destructive testing as per BIS Code requirement.
 - viii. All gauges, templates, jigs, fixtures, instruments necessary for inspection and testing shall be provided by the successful bidder during for the purpose of inspection.
 - ix. To ensure effective in-process Quality Control, it is essential that the manufacturer should have all testing facilities for tests like, weight of zinc coating, tensile & shear strength, non-destructive testing of welds etc. in house.
 - x. Each piece of steel work shall be distinctly marked before delivery in accordance with marking diagram and shall bear such and other marks as well to facilitate erection.
 - xi. **The successful bidder shall ensure that the steel work shall be temporarily shop erected complete or part, so that accuracy is checked before dispatch.**
 - xii. Each individual Tower Member shall carry a stamped mark (Number) assigned to in the approved drawings. These stamping shall be done

by a metal die of 16mm size before galvanizing and on optimum depth so as to be clearly legible after galvanizing. In addition, the mark number should be stenciled in indelible ink on each Tower Member after galvanizing.

- f. **Pre-dispatch inspection of fabricated tower materials shall be carried out by Inspecting Officer deputed by the authorized representative of this Office at successful bidder's works. The Bidder shall provide all necessary facilities to the Inspecting Officer for the purpose.**

14. PAINT & PAINTING

- a. The lattice steel portion of Tower shall be painted after complete erection as given below.
 - i. One coat of Zinc rich Epoxy Primer conforming to IS:5666 (with latest amendments)
 - ii. Final two coats of Synthetic enamel paint conforming to IS:2932, (colour: international Orange & White). The two final coats of paint on Tower shall be painted with Synthetic enamel paint conforming to IS:2932, to have alternate band of International orange and white Colours, with top and bottom bands painted in International orange as per Civil Aviation Regulation. Width of orange band shall be double the width of white band.
- b. The paints used in painting shall be of best quality from reputed paint manufacturer such as British, Asian, Berger, Shalimar, Nippon Paints in accordance with relevant BIS Codes.

15. FACILITIES ON TOWER

a. Platform

Provisions of platform for access to the Antennas, aviation lights and cables at different levels shall be made as indicated in Working Platform drawings.

- i. 1.5m high handrail with expanded metal shall be provided around the platform for safety.
- ii. Platform shall have chequered plated flooring of suitable thickness not less than 6mm.

b. Climbing Ladders:

- i. An internal ladder of dimensions as in drawings starting from the ground level and going up to the top with openings at all the platforms shall be provided.
- ii. The ladder shall be suitably hooped for safety of the climbing personnel.
- iii. The location of climbing ladder should be in the vicinity to the vertical cable rack so as to make the rack accessible for hauling up and clamping of the RF feeder cables. It should be located in the center or on one of the faces of tower or at corner, as per drawing.
- iv. Rungs of the ladder shall be clear of any obstructions to the climber, equally spaced as per drawing.

c. Cable Rack :

- i. The vertical cable rack and clamps for support of RF Feeder Cables from the base of the Tower to the antenna at the top, shall be routed as per cable rack drawings.
- ii. **The rungs of vertical cable rack shall be extended by 200mm on each side in addition to the length shown in the drawing to accommodate power cables required for AOL and power sockets in each platform. The size of the steel members of extended portion shall be the same as that of rungs of the cable rack.**
- iii. Horizontal Feeder Cable Rack to support RF Cables on ground from Tower Base to the Transmitter Hall shall also be fabricated by the successful bidder. The Horizontal Cable Rack shall be as per details in suggestive Drawing for a length of 40m (approx).
- iv. Exact level and the route and length of horizontal Rack shall be decided at site as per site conditions in consultation with DD. Actual layout as per site condition shall be submitted by the successful bidder for approval.
- v. The horizontal cable rack is to be covered by Galvanized iron-sheets .
- vi. **The Successful Bidder shall quote on the basis of unit length rates for the horizontal rack.**

d. Protection against Lightning & Earthing :

- i. Principle of Protection: The fundamental principle for the protection of Tower against lightning is to provide a conducting path between the general mass of earth and the atmosphere above the Tower by which a lightning discharge may enter the earth without producing dangerous potential differences in or near the Tower.
- ii. The materials for the lightning conductors, down conductors , earth termination network etc. of the protective system shall be reliably resistant to corrosion or be adequately protected against corrosion. Only copper materials shall be used. The flat copper strip used, shall be of grade, ordinarily required for commercial electrical work, generally designated as being of 98% conductivity when annealed. They shall conform to the relevant Indian Standard Specification. The minimum size of Copper Strip shall be 25mm x 5mm.
- iii. **Lightning arrestor will be provided by the Department and lighting conductor (Two Copper strips of size 25 x 5mm) shall be provided by the successful bidder.**
- iv. The down conductor shall run along the ladder and follow the most direct path avoiding sharp bends, upturns and kinks.
- v. The down conductor shall be insulated from the main structure / ladder with the help of ceramic insulators fitted at least at every one meter distance. A schematic arrangement showing the mounting of Lightning Arrestors, Down Conductor, Insulators etc. shall be submitted to DD for approval by the successful bidder.
- vi. Two separate copper earth strips, drawn from lightning arrestor system, insulated from tower structure and properly clamped, shall be connected to two separate earth electrodes on the ground.

- vii. The tower shall be provided with suitable complete system of lightening protection in accordance with provision of IS:2309 (with latest amendments) and approved drawings, considering necessary earthing based on the specific resistivity of the soil and sub-soil water level and other relevant provision stated there off.

e. Earthing :

- i. **Earthing of the tower and electrical accessories shall be carried out as per drawing provided.**
- ii. All tower legs shall be connected to ground properly as per standard practice of earthing of such structures. Each down conductor shall have independent earth termination. All earth terminations shall be interconnected. Earth electrodes shall be constructed and installed in accordance with IS:3043 (with latest amendments).
- iii. The earth resistance value of all earth pits **should not exceed one ohm.**

16. CALCULATION OF WEIGHT FOR PAYMENT

- i. The weight of tower shall mean the weight of tower calculated by using the black sectional (i.e. ungalvanized) weights of all steel members of the sizes indicated in the Structural / Assembly / Erection Drawings and Bill of Materials without taking into consideration the reduction in weight due to drilling of bolt/rivet holes etc. or increase in weight due to galvanizing.
- ii. Unless otherwise specified the payment for all items shall be made as per Agreement rates.
- iii. Unless otherwise specified, for item of erection, the payment shall be made on weight basis. The weight shall be calculated as under.
- iv. The actual dimension (length & width) of the members shall be measured in running meters correct to a centimeter & the thickness shall be measured correct to a millimeter.
- v. For calculation of weight, the coefficients as given in the standard tables of B.I.S. Codes shall be followed.
- vi. In case the coefficients are not available in B.I.S. Codes, then the coefficient available in standard tables shall be followed.
- vii. In case none of the above is possible, the actual weight shall be measured at site before erecting.
- viii. Suggestive weight of the tower is indicated in bill of materials. However payment will be made on actual weight of the material as calculated above.

17. ELECTRICAL REQUIREMENT FOR TV TOWER

- a. Supplying and laying of following size copper armoured UG cables of 1.1 KV grade and appropriate rating conforming to relevant IS codes from LT panel to tower base and tower base to individual power sockets and AOLs in platforms, in following modes as required as per site condition.
 - i) Direct in ground including excavation, sand cushioning, protective covering and refilling.
 - ii) In PVC/ metallic pipes.
 - iii) In masonry open duct/for loop/connections etc.
 - iv) On Cable tray

- b. Supplying & fixing of pre painted perforated GI cable trays of size 150mm (w) x 50mm(D) x1.6mm (thick) to the tower / vertical rack to route the electrical cables mentioned above from tower base to individual landing power sockets/ AOLs.
- c. Supply and laying of 10 Sq.mm, 4-core copper cable, armoured, weather proof, PVC sheathed of standard make to be provided from main LT panel to Distribution board at the bottom of the tower.
- d. Supply and laying 1No.of 2.5 Sq.mm. 3 core 600 V rating Copper cable (armoured ,weather proof PVC sheathed) from power distribution board at tower base to each platform, for the service out lets.
- e. Supply and laying of 4 sq.mm 3 core copper Cable (armoured, weather proof PVC sheathed) from power distribution board at the bottom of the tower to each AOL at all the respective five platforms. Separate cable to be laid for each individual aviation light.
- f. Supply and installation of weather proof, dust and vermin proof, enclosure of size 1000 x 1000x 500mm, floor mount, fabricated with 2mm thick (14 SWG) CRCA sheet with double door, at the front side, with inbuilt locking arrangement to house suitable bus bars, earth bars for terminating incoming power cables from LT panel and outgoing power cables to AOLs and Power sockets in the platforms. The enclosure shall be suitably installed on MS Channel, grouted in RCC foundation at the base of the tower. The enclosure shall be painted with grey colour powder coated finish. All necessary connections and interconnections shall be made. Supplying and installing of MCBs of reputed make, as given in BoQ. Make of the offered MCBs shall be mentioned in the technical bid.
- g. Supply and fixing weather proof PVC box of size 280 x 170 x 130 mm (nominal), one in each platform, with suitable GI clamp / fixing arrangement on existing angle iron channel having front open cover with locking arrangement with 3mm thick phenolic laminated sheet base for housing 5/15mm power socket and 5/15A piano switch.
- h. Supplying and fixing 6 pin 5/15 A socket and 5/15 A piano switch of reputed make, 1 set in each platform.
- i. Supply & Installation of aviation obstruction lights of reputed make on Tower as per ICAO Norms and as enumerated in Para 18 below. A.O.L. shall be approved by Doordarshan authorities.
- j. Installing Flashing Aircraft Warning Light System (AWLS), at the top of Band IV antenna, which will be provided by the department. Supplying and laying of electrical cables of suitable size for the AWLS, Provision of Automatic sun-switch is to be made for operating the Aviation Lights.
- k. Detailed drawing showing all electrical works, wiring, connections etc. shall be submitted by the successful bidder and obtain the approval of competent authority, before taking up the works.
- l. All electrical cables supplied should be of reputed make. Make of the offered cables shall be mentioned in the technical bid.

18.ADDITIONAL CONDITIONS FOR EXECUTION OF ELECTRICAL WORKS

- a. All works shall be carried out as per CPWD general specifications for Electrical works with up to date amendments.

- b. All Electrical materials to be used shall conform to the following.
 - i) Shall be as mentioned in the schedule of quantity.
 - ii) Shall be as per the additional conditions attached with the tender document.
 - iii) The materials should be ISI marked. If ISI marked material is not available it should be conforming to ISI specifications and the same should be got approved by the Engineer – in- charge.
 - iv) If material conforming to IS Specification is not available ,the materials used shall be got approved from the Engineer-in charge.
- c. Bad workmanship is liable to be rejected.
- d. The agency/ his supervisor will be bound to sign the site order Book and to carry out the instruction given there in.
- e. The wiring / conduit routes shall be marked at site first and got approved from the Installation Officer, before the start of actual work.
- f. Unless otherwise mentioned in the schedule of work the contractor shall preferably use the following make of the materials ISI marked in the work.
 - i) 5/15 Amp switch and socket : ANCHOR / HAVELLS
 - ii) All copper conductor cable / wires shall be PVC insulated , Fire retardent (FR) or Fire retardent low smoke (FRLS) type confirming to BIS Specification.
 - iii) UG cable : UNIVERSAL/ POLYCAB / Havells / Finolex / V-Guard.
 - iv) Wiring cable : FINOLEX / L&T / ANCHOR / HAVELL's, Polycab.
 - v) GI PIPE: Tata / Zenith / Apollo / Prakash / Zindal
 - vi) Ammeter, Voltmeter, power factor meter : Havells / MECO / AE
 - vii) MCBs : Havells / Standard / Legrand / Indo kopp / Haiger
 - viii) MCCBs : L& T / Seimens / C & S.
 - ix) PVC Conduit : Precision / Avonplast / Sudhakar
- g. In case the particular makes of materials mentioned under condition above are not available at the time of execution the alternative make of materials has to be approved from the Installation Officer.
- h. Aluminium alloys/Cadmium plated iron screw/brass screw only shall be used in the work.
- i. The earthing shall be carried out as per drawing, in presence of Installation Officer or his authorized representatives.
- j. Thimbles are to be provided where ever required without any extra charges for cable termination of size 2.5 sq.mm & above.

19. AVIATION OBSTRUCTION LIGHTS (A.O.L.)

- a. LED based Aviation Obstruction Lights which are to be installed in the platforms should be provided by the successful bidder. The globes and their housings shall be strong, weather proof and of approved manufacturer.
 - i) In 40m platform, 4 nos. low intensity AOL shall be provided.
 - ii) In the platforms at 80m and 126m level, 2nos. of Medium intensity – Type B, AOLs (in each platform) shall be provided.

- iii) In the platform at 105m level, two nos. of low intensity – Type B, AOL shall be provided.
 - iv) In the platform at 150m level, one no. of medium intensity AOL – Type B shall be provided.
 - v) Aviation Obstruction lighting arrangement shall be as per latest International Civil Aviation Organization Rules. Specification for AOLs are given in Annexure V & VI.
- b. The AWLS to be mounted above the Band IV antenna will be provided by the Department for which suitable power supply cable should laid from the distribution board up to the top of the tower.
 - c. Power supply connection to the aviation lights shall be made such that loads are evenly distributed on all the three phases in order to ensure that with failure of the single phase all the lamps at each level do not go off. The power supply cable for the lights shall conform to IS:1554 (with latest amendments).
 - d. The Bidder shall provide temporary Aviation Obstruction Lights during erection of Tower as soon as the Tower reaches 45 meters.
 - e. AOL control monitoring panel shall be provided in the power supply room of the Transmitter Building.
 - f. A "SUN Switch" is required to be provided for aviation lights so that these are "ON" automatically if sufficient sunlight is not available around Tower. In no case SUN Switch is to be installed inside a room or covered space.
 - g. The details of Power Supply arrangements for aviation lights shall be provided by the successful bidder.
 - h. Each light must be connected using separate power cable.**
 - i. The LED based AOL offered shall be approved by National Physical Laboratory (NPL) and Make and Model of offered AOL shall be mentioned and catalogues shall be submitted with the offer. Manufacturer's Test Reports for the AOL must be submitted by successful bidder along with the material supply.
 - j. The Detailed Internal Circuit Diagram of the AOL, No. of LEDs used, details of configuration of LEDs (series parallel arrangement etc.) shall be submitted by the successful bidder.

20. INSTALLATION OF ANTENNA SYSTEM

- a. After the erection of the Tower, the successful bidder shall also haul up UHF TV Antenna (Band IV), 2 Nos. of 4" dia. RF cables, AIR FM Panel type Antenna along with two RF Cables, associated Junction Boxes etc. on the Tower as per details provided by respective manufacturers / DD. The Antennae system and RF Feeder Cables will be provided by DD.
- b. For the sake of completeness of works, the successful bidder may have to undertake minor / major items of works that may become necessary for the mounting of Antenna System mentioned hereto, without any additional cost.

21. THIRD PARTY CERTIFICATION:

Successful bidder shall obtain stage-wise third party Certificate for satisfactory completion of works. **The third party certifying Authority shall be a domain expert in the relevant field. The successful bidder shall engage IIT/NIT/ SERC for third party certification for the following scope.**

- a. To Inspect and certify whether Tower foundation works and materials are complying to the Technical Specifications laid in the Tender, during and on completion of the Tower foundation works .
- b. To check whether quality of all materials in each batch of supply by the successful bidder is complying to the Technical Specifications laid in the Tender.
- c. To examine and certify whether the workmanship (fabrication and erection) is satisfactory and work is carried out as per technical Specifications laid in the Tender, at each stage.
- d. To examine and certify whether verticality of the tower is well within the allowable tolerance as stipulated in the tender, during and after tower erection.
- e. **Successful bidder shall specify the certifying authority proposed to be engaged for Third Party Certification. A letter of acceptance from the proposed certifying authority to this effect shall be produced, and approval of Doordarshan obtained, before taking up the work.**

22. DOORDARSHAN SUPPLY :

The Doordarshan shall supply to successful Bidder the following:

- a. UHF Band IV Antenna to be mounted on 150 m level.
- b. 2 Nos. of 4" diameter R.F. Feeder Cables for TV antenna.
- c. One no. of AWLS (Aviation Warning Light System) to be mounted on the top of the Band IV Antenna.
- d. AIR FM antenna and associated RF feeder cables.
- e. Lightening arrestor.
- f. Complete Design and fabrication drawings required for erection.

23. INSPECTION AND SITE ACCEPTANCE TEST

ATP; Acceptance Test Procedure (ATP) must be submitted by the successful bidder within six month of acceptance of work order. The ATP shall be approved by Doordarshan after necessary modifications, if required. The approved ATP shall be sent back to the Bidder to be used for inspection of Tower by DD Representatives.

24. GUARANTEE

- a. The successful bidder shall guarantee to replace free of charge any material or part thereof that may develop defects within the guarantee period of the Tower. The guarantee period shall be **five years** from the date of completion of erection of the Tower, or **three years** after the erection of the Antenna System **whichever is later.**
- b. All Electrical / Electronic Parts / Materials such as AOL, Beacon Light, Control Panels, cabling wiring to lights, shall be guaranteed for two years from the date of handing over except for items supplied by Doordarshan.
- c. The successful bidder shall guarantee the stability, safety, durability and satisfactory behavior of the Tower structure under all conditions of specified loading and complete system and part there off including allied systems.
- d. Should any defects be noticed in design, material and /or workmanship within the guarantee / warranty period the organization shall inform Supplier/ Contractor and Supplier/ contractor shall immediately on receipt of such intimation, depute their personnel within 14 days to investigate the causes of

defects and arrange rectification / replacement/ modification of the defective items /material / work at site without any cost to the Organization within a reasonable period.

25.INSURANCE

- a. The successful bidder shall arrange insurance for all workers engaged by the bidder as per prevailing labour rules at his own cost.
- b. The successful bidder shall also take workmen's compensation insurance as required by Law and undertake to indemnify and keep indemnified the Doordarshan, from and against all manner of claims and demands and losses and damages and cost (including between attorney and client) charges and expenses that may arise in regard the same or that the Doordarshan may suffer or incur with respect to and or incidental to the same.

26.COMPLETION OF TOWER

- i. Tower complete in all respects is to be jointly inspected at site by the Representatives of firm, Officers from Doordarshan.
- ii. The Tower structure shall be inspected in the presence of Representative of DD and Third party approved by Doordarshan for its structural firmness, verticality and all other design specifications. Inspection Report with all the observations, recommendations etc. shall be submitted. The recommendations / suggestions will have to incorporated if approved by DD before submitting the Final Completion Report. All costs on this inspection and post inspection corrections, if required for completeness of the Tower shall be borne by the successful bidder.
- iii. The arrangements of equipment for checking the verticality is to be arranged by the successful bidder
- iv. The Earth-Resistance of the Tower shall be tested by Representative of DD at Site.
- v. The Aviation Lights on the Tower should function as per Doordarshan Specifications and the same will be checked by DD Representatives.
- vi. Necessary tools, equipment etc. for checking / verification shall be arranged by the successful bidder at site.
- vii. All debris, extra-material and items etc. which are brought / created during construction work at site are to be removed / cleared by the successful bidder.
- viii. **For the sake of completeness of SETC of the 150m tower, the successful bidder may have to undertake minor / major items of works that may become necessary for the completion of SETC of the 150m tower, without any additional cost.**

27.MARKING OF MEMBERS

Each individual Tower Member shall carry a stamped mark (number) assigned to in the approved drawings. These stamping shall be done by a metal die of 16mm size before galvanizing and on optimum depth so as to clearly legible after galvanizing. The marking should also include description as 'TVT 150M/MBNR' in addition to other detail.

28. PACKING

The material should be boxed or bundled for transport in the following manner :

- a. Angle shall be packed in bundles securely wrapped four times around at each end and over 900mm with 9 SWG Gauge wire with ends twisted tightly. Gross weight of any bundle shall not exceed 450Kg.
- b. Angles, brackets, plates and similar small loose pieces shall be tested and bolted together in multiples and securely wired together through holes wrapped round at least four times with No.9 SWG steel wire and ends twisted tightly. Gross weight of each bundle shall not exceed 70 Kgs.
- c. The correct numbers of bolts, nuts and washers plus extra bolts, nuts and washers for the Tower shall constitute a packing unit and shall be dispatched packed in crates or wooden boxes strong enough to withstand the normal vigorous transit and handling. The various sizes of bolts, nuts and washers shall be kept in separate bags inside the main container. Each container shall carry a list of the bolts contained therein printed in water-proof ink, resistant to moisture. Weight of the container shall not exceed 70 Kgs.

29. MARKING PACKAGES

Each bundle or package shall have the following details marked on it.

- a. The name and address of the Consignee.
- b. The relevant marks and number of Tower Members or reference of bolts, nuts and small components like gusset plates, various attachments etc. for easy identification.
- c. The marking shall be stenciled in indelible ink on the top member of the bundle of tower steel and on wooden boxes or gunny bags containing smaller components.
- d. DD shall, in no case, be responsible for loss of any package or bundle during transit. It shall be the responsibility of the Bidder to replace the lost items free of cost.

30. LIST OF DRAWINGS

Sl.No	Particulars	Drawing No.
1	Construction of 150M. Self Supporting Tower at Mahabubnagar	JTT/IIT(M)/AIR/150-44/GA/01
2	Rock Anchor Foundation Drawing for 150M. High Square Tower SBC:589 kpa(Hard Rock) 2Nos	JTT/IIT(M)/DEC/16/05/DD/272/FDN
3	Drawing of Horizontal cable rack	
4.	Drawing for antenna interface	
5.	Drawing for earthing	

31. TERMS OF PAYMENT

a. For Foundation Work :

- i. 80% of foundation cost will be paid on completion of foundation and on submitting Certificate from third party and by authorised Doordarshan Official.
- ii. Remaining 20% of foundation cost will be paid after handing over of tower.

b. For Supply of tower material :

- i. 80% of the total cost of material supplied **in sync with the schedule for erection described in point c below,** will be paid on submitting Certificate from third party and by authorised Doordarshan Official and satisfactory receipt of materials at site. The firm will raise not more than four bills for supply of entire quantity of tower materials.

Note : The supply of material shall **be in sync** with the schedule for erection described in point c below.

- ii. Balance 20% on supply of materials will be paid after completion of erection and handing over of the tower.

c. For Erection of 150 m Tower : (Annexure IV- Suggestive BoM - B 2)

- i. 80% of the erection cost for the weight of the materials used for completing the erection up to the height of 30m.
- ii. 80% of the erection cost for the weight of the materials used for completing the erection up to the height of 60m.
- iii. 80% of the erection cost for the weight of the materials used for completing the erection up to the height of 90m.
- iv. Balance erection cost will be paid on completion and handing over of the tower.

d. Cost of supply of materials and installation charges for items other than mentioned in a, b & c of this clause will be paid after satisfactory completion of SETC of the tower and handing over.

e. Quantities mentioned in this tender are tentative. Payment will be released according to actual measurement.

f. All payments will be made on submission of third party Certificate and Inspection by authorized Doordarshan Official.

SPECIAL CONDITIONS FOR SUPPLY OF TOWER MATERIAL

The following special conditions shall be applicable for supply of tower materials in addition to the other conditions given in the schedule of quantities. However, nothing extra shall be paid on this account unless otherwise specifically mentioned:

1. The bidder shall procure all structural steel members i.e., angles, tees, plates, nuts and bolts etc conforming to relevant IS codes from main producers as approved by the Ministry of Steel namely SAIL, TISCO, ISCO, RINL, JINDAL. In exceptional cases when the bidder is required to procure any structural steel members conforming to relevant IS codes from other than main producers, it can be done with prior approval of Installation Officer. The bidder shall have to obtain and furnish test certificate to the Installation Officer in respect of all supplies of steel members brought by him to site of work. Samples shall also be taken and got tested by the Installation Officer as per the provisions in this regard in the relevant IS codes. In case the test results indicate that the steel arranged by the bidder does not conform to IS codes, the same shall stand rejected and shall be removed from the site of work within three days from written order of the Installation Officer.
2. The steel structural members shall be stored by the bidder at site of work in such a way as to prevent distortion and corrosion and nothing extra shall be paid on this account. Members of different sections and sizes shall be stored separately to facilitate easy checking.
3. For testing of steel members in accordance with IS 2062 (1999) specimen of sufficient length shall be cut from sectional member of steel as per requirement of relevant IS codes and the bidder shall supply free of charges the steel members for testing.
4. The cost of tests of structural steel, fasteners and foundation material shall be borne by the bidder / Doordarshan in the manner indicated below:
 - a) By the bidder, if the results show that the structural steel, fasteners and foundation material do not conform to the relevant BIS codes.
 - b) If the results show that the structural steel, fasteners and foundation material conform to the relevant BIS codes, expenditure incurred by the bidder for the tests shall be reimbursed by Doordarshan.
5. The bidder shall produce documentary proof of having placed orders for procurement of tower materials within 30th day of acceptance of work order by the bidder. Failure to comply with this condition shall make the contract cancelled and the EMD forfeited without any further notice.

GENERAL GUIDELINES FOR ERECTION OF TOWERS

1. Tower erection work and method of erection shall be planned considering tower erection site, tower height, tower members, weight of materials to be lifted etc.
2. The tower members shall be arranged member by member and quantity shall be checked according to drawings supplied / bill of quantities etc. before start of erection work.
3. In case, any members are bent or twisted they shall be straightened up.
4. In tower erection work, erection order shall be observed and tower orientation accurately carried out. In assembling, members shall be successively fitted on the position shown in the details of towers. Necessary precautions shall be taken while lifting the materials.
5. A walkie-talkie may be used as erection progresses to the upper part of the tower, for communication between workers on the ground and those on the top.
6. Bolts and nuts should be fitted in position (as shown in drawings) as assembly progresses. Bolts in horizontal level shall be inserted from inside of towers with nut applied on the outside of the tower. Bolts in a vertical line shall be inserted from beneath with nuts applied on upside.
7. During erection, bolts and nuts shall be tightened in the following order:
In the first place, the first and second sections of tower shall be assembled with bolts and nuts tightened tentatively.
In the second place, the third section shall be assembled and tentatively tightened and at the same time the first section be completely tightened after it has been confirmed that the section is accurately assembled. The remaining part of the tower shall be checked for proper tightening.
8. During the erection work, it shall be confirmed by means of measurement (with a transit theodolite or total station) that the tower is accurately assembled by redressing possible twist and bend etc. on the tower.
A transit theodolite or total station shall be set along with each of the two lines crossing perpendicularly at the tower centre and measurement made to see that connecting line between centre of bolts or faces of sections already assembled are perpendicular against the ground. In case this is not so, the portions shall be redressed before assembling upper part.

STANDARDS / CODES

The fabrication, galvanizing, testing, erection procedure and materials used for manufacture and erection of towers, construction of foundation shall conform to the following Indian Standards (IS) which shall mean latest revisions, with amendments / changes adopted and published, unless specifically stated otherwise in the Specification.

S. No.	IS Code	Title
1	IS:800	Code of Practice for General Construction in Steel
2	IS:456	Code of Practice for Plain and Reinforced Concrete
3	IS:10270	Guidelines for Design and Construction of Prestressed Rock Anchors
4	IS:1367	Technical Supply Conditions for Threaded Steel Fasteners
5	IS:6639	Specification for Hexagon Bolts for Steel Structures
6	IS:1363	Hexagon Head Bolts, Screws and Nuts of Product Grade 'C'
7	IS:1573	Specification for Electroplated Coatings of Zinc on Iron and Steel
8	IS:1024	Code of Practice for use of welding in bridges and structures subject to dynamic loading
9	IS:9595	Metal arc welding of carbon and carbon manganese steels – Recommendations
10	IS:7215	Tolerances for Fabrication of Steel Structures
11	IS:2629	Recommended Practice for Hot-Dip Galvanizing of Iron and Steel
12	IS:4759	Hot-Dip zinc coatings on structural steel and other allied products
13	IS:2633	Methods for testing uniformity of coating of zinc coated articles
14	IS:3203	Methods of testing local thickness of electroplated coatings
15	IS:5358	Specification for galvanization of Bolts and other fasteners
16	IS:2062	Steel for General Structural Purposes – Specification (June 1997)
17	IS:1852	Rolling and cutting tolerances for hot rolled steel products
18	IS:2500	Sampling Procedure for Inspection by Attributes
19	IS:808	Dimensions for Hot Rolled Steel Beam, Column, Channel and Angle Sections
20	IS:4000	High Strength Bolts in Steel Structures – Code of Practice
21	IS:5666	Specification for Etch (Pretreatment) Primer
22	IS:2932	Specification of synthetic enamel paint
23	IS:8112	Specification for 43 grade ordinary Portland Cement
24	IS:383	Specification for Coarse and Fine Aggregates from Natures Sources for Concrete
25	IS:432	Specification for Mild Steel and Medium Tensile Steel Bars and Hard-Drawn Steel Wire for Concrete Reinforcement
26	IS:1139	Specification for high strength deformed steel bars and wires for concrete reinforcement.
27	IS:1786	Specification for high strength deformed steel bars and wires for concrete Reinforcement
28	IS:2502	Code of Practice for Bending and Fixing of Bars for Concrete Reinforcement
29	IS:3043	Code of Practice for Earthing
30	IS:1554	PVC Insulated (heave duty) electric cables
31	IS:816	Code of Practice for use of metal arc welding for general construction in mild steel

S No	I S Code	Title
32	IS:3502	Steel Chequered Plates – Specifications
33	IS:209	Zinc Ingot – Specification
34	IS:1566	Specification for Hard-drawn Steel Wire Fabric for Concrete Reinforcement
35	IS:12843	Tolerances for Erection of Steel Structures.
36	IS: 10262: 2009	Concrete Mix Design

SUGGESTIVE BILL OF MATERIALS / LIST OF DELIVERABLES (UNPRICED)
PART:I (CIVIL)

Sl.no	Descripton	Qty	Unit
1	Earth work in excavation by mechanical means (Hydraulic excavator)/manual means over areas (exceeding 30 cm in depth, 1.5 m in width as well as 10 sqm on plan) including getting out and disposal of excavated earth lead upto 50 m and lift upto 1.5 m, as directed by Engineer-in-charge		
	a)All kinds of soil	350	Cum
	b)Hard rock (blasting prohibited)	410	Cum
	c) Drilling of two sets of 36 Nos (6x6 array with spacing of 1150mm)of holes of dia 100mm upto a depth of 3500mm in hard rock, placing of rock anchors (Fe 415 of 50mm dia) in the holes and grouting with cement grout of grade M25 (With non shrinkage compound)	260	metre
	d) Drilling of two sets of 36 Nos (6x6 array with spacing of 950mm)of holes of dia 75mm upto a depth of 2900mm in hard rock, placing of rock anchors (Fe 415 of 42mm dia) in the holes and grouting with cement grout of grade M25 (With non shrinkage compound)	220	metre
2	Extra for every additional lift of 1.5m or part thereof in excavation /banking excavated or stacked materials.		
	a)All kinds of soil	268	Cum
	b)Ordinary or hard rock	180	Cum
3	Filling available excavated earth / moorum (excluding rock) in trenches, plinth, sides of foundations etc. in layers not exceeding 20cm in depth, consolidating each deposited layer by ramming and watering, lead up to 50 m and lift up to 1.5 m.	240	Cum
4	Supplying and stacking at site.		
	a) Moorum	240	Cum
5	Providing and laying in position ready mixed plain cement concrete, with cement content as per approved design mix and manufactured in fully automatic batching plant and transported to site of work in transit mixer for all leads, having continuous agitated mixer, manufactured as per mix design of specified grade for plain cement concrete work, including pumping of R.M.C. from transit mixer to site of laying and curing, excluding the cost of centering, shuttering and finishing, including cost of curing, admixtures in recommended proportions as per IS : 9103 to accelerate/ retard setting of concrete, improve workability without impairing strength and durability as per direction of the Engineer-in-charge.” Note : Excess/less cement used than specified in this item is payable/ recoverable separately.		
	All works upto plinth level :		
	M-10 grade plain cement concrete (cement content considered @ 220 kg/cum) cum	45	Cum
6	Centering and shuttering including strutting, propping etc. and removal of form for :		
	a)Foundations, footings, bases of columns, etc. for mass concrete.	490	Sqm
7	a)Steel reinforcement for R.C.C. work including straightening, cutting,	2000	Kg

	bending, placing in position and binding all complete up to plinth level.		
	b)Thermo-Mechanically Treated bars	17100	Kg
8	Anchor rods Providing and laying in position ready mixed M-25 grade concrete for reinforced cement concrete work, using cement content as per approved design mix, manufactured in fully automatic batching plant and transported to site of work in transit mixer for all leads, having continuous agitated mixer, manufactured as per mix design of specified grade for reinforced cement concrete work, including pumping of R.M.C. from transit mixer to site of laying , excluding the cost of centering, shuttering finishing and reinforcement, including cost of admixtures in recommended proportions as per IS : 9103 to accelerate/ retard setting of concrete,improve workability without impairing strength and durability as per direction of the Engineer-in-charge.		
	(Note :- Cement content considered in this item is @ 330kg/cum. Excess/less cement used as per design mix is payable / recoverable separately)		
	a)All works up to plinth level.	740	Cum
	b)Add for using extra cement in the items of design mix over and above the specified cement content therein. quintal	120	quintal
9	Random rubble masonry with hard stone in foundation and plinth including levelling up with cement concrete 1:6:12 (1 cement : 6 coarse sand : 12 graded stone aggregate 20mm nominal size) up to plinth level with :		
	Cement mortar 1:6 (1 cement : 6 coarse sand) cum 3965.85	58	Cum
10	Providing and Fabricating of hot dip galvanised steel tower materials consisting of angles, flats, base plates, gusset plates, chequered plates, ladders, vertical cable racks, working platform with railings, antenna fixtures for Band II,III,IV & V connecting plates etc. complete. All fabricated members are as per approved design drawings and specifications. Galvanising thickness shall be as per latest relevant standards.	2,50,000	Kg
11	Supply and fixing anchor bolts nuts and templates to the steel tower foundation as per the approved drawing and specifications.	5000	Kg
12	Supplying of hot dip galvanised MS fasteners of class 8.80 Grade as specified in IS 1367.	18000	Kg
13	Erection of tower as per approved structural design and drawing with all its necessary components viz, climbing ladder, working platform with railings, antenna fixtures, vertical cable rack/tray, pipe stands for lightning arrestor fixing with bolts, nuts and spring washers, necessary welding etc., wherever required complete in all respects as per the direction of Engineer-in-charge. The rate shall include cost of all operations involved in hoisting and erection of tower.	2,50,000	Kg
14	Painting of tower as per specification with two coats of synthetic enamel paint of approved brand and colour (International White & Orange) over and one coat of zinc rich epoxy primer conforming to IS 5666 (with latest amendment) as per recommendation of civil aviation regulation for tower. The rate shall include supply of all paint materials, painting of tower platform, antenna mount, ladder, vertical tray, horizontal tray, post, etc. required for completion of tower in all respects.	1	job

15	Mounting and hauling of Band IV Television antenna system at 150m level and routing of RF Feeder cables along the vertical cable rack and from tower to the transmitter building as per the specification and direction of the Engineer-in-charge(Antenna and feeder cable to be made available at the site by Doordarshan for hauling).	1	job
16	Supplying and installation of horizontal feeder cable rack from tower base to transmitter building as per the approved design and drawing.	3000	Kg
17	Supplying and installation of antenna interface for Television antenna and FM panel antenna as per the approved design and drawing.	3000	Kg
18	Hauling up of FM panel antenna and 2 nos of feeder cables.The antenna shall be mounted on the four sides of the tower. Antenna ht : 18m; Weight : 2000Kg (Approx)		
19	Third party inspection charges	1	job
	ELECTRICAL		
1	Supply of LED Aviation obstruction light of following type and control panel including installation etc., as required.		
	a) Low intensity LED Aviation obstruction light (conforming to ICAO type B) at 40m platform(4 nos) and 105m platform (2 nos) (Binay, Model:A/LI-300 or similar approved)	6	No.
	b) Medium intensity LED Aviation obstruction light (conforming to ICAO type B) two each at 80m & 126m and one no at 150m platforms. (Make: Binay, Model:MI-DX 1200 or similar approved)	5	No..
	c) Flasher synchronisation control and monitoring system for LED Aviation obstruction lights	1	No.
2	Supplying and installing following size of perforated pre-painted M.S. cable trays with perforation not more than 17.5%, in convenient sections, joined with connectors, suspended from the ceiling with MS suspenders including bolts and nuts, painting suspenders etc as required.(on existing tower members)		
	a)150 mm width X 50 mm depth X 1.6 mm thickness	160	metre
3	Supply of following size copper armoured UG cable confirming to IS: 1554 (part I) with up to date amendments of 1.1KV grade in following modes as required		
	a) 4x10 sq.mm	160	metre
	b) 3x2.5 sq.mm		metre
4	Laying of following size copper armoured UG cable confirming to IS: 1554 (part I) with up to date amendments of 1.1KV grade in following modes as required		
	A) 4x10 sq.mm (from LT panel to tower base)		
	a) Direct in ground including excavation, sand cushioning, protective covering and refilling	100	metre
	b) In existing PVC/SW/HDPE/Metallic pipes	30	metre
	c) on surface	15	metre
	d) In masonry open duct/for loop/connections etc	15	metre
	B) 3x2.5sq.mm (from tower base to individual landing power sockets)		
	a) on cable tray	190	metre
	b) In masonry open duct/for loop/connections etc	10	metre
5	Supply of 3x4 sq.mm copper armoured cable confirming to IS: 1554 (part I) with up to date amendments of 1.1KV grade	1380	metre
6	Laying and fixing of 3x4 sq.mm copper armoured cable confirming to IS: 1554 (part I) with up to date amendments of 1.1KV grade on tower		

	(existing cable tray) with suitable fixing arrangement and connections with copper thimbles etc., as required.(Note: Individual cable from control panel to each aviaiton light has been considered)		
	a) from control panel to aviataion lights at 40m platform	200	metre
	b) from control panel to aviation lights at 80m platform	300	metre
	c) from control panel to aviation lights at 105m platform	400	metre
	d) from control panel to aviation lights at 126m platform	300	metre
	e) from control panel to aviation lights at 150m platform	180	metre
7	Supplying and installation of outdoor weather proof box size 1Mx1Mx500mm(approximate), fabricated with high quality 2mm thick(14SWG) CRCA sheet with double door at front side and inbuilt locking arrangement, floor mounting and totally enclosed, dust and vermin proof capable to operate on 415V , 3phase 50Hz. AC supply provided with suitable bus bar, din bar and earth bus for incoming and outgoing connection. The board should have slanted top covers and danger notice board, with providing and fixing the following accessories thereon 6mm thick phenolic laminated sheet. The panel shall be erected on MS channel for grouting in the RCC foundation i/c providing foundation, painting with grey colour powder coated finish, complete with connections, interconnections, sign writing, thimbles/lugs, cable knockout etc., as required (for terminating cable from LT panel and outgoing cable to landing power sockets and aviation lights)	1	Set
	a) 63A 4pole MCB - 1 (One) No (Make: Legrand/siemens/Haiger) (Inclusive)		
	b) 32A 4 pole MCB- 1 (One) No (Make: Legrand/siemens/Haiger) (Inclusive)		
	c) 6A SPN MCB -10 Nos (Make: Legrand/siemens/Haiger) (Inclusive)		
8	Supplying and fixing one number weather proof PVC box of size 280x170x130mm (nominal) with suitable size GI clamp/fixing arrangement on the existing angle iron channel having front opening cover with locking arrangement with 3mm thick phenolic laminated sheet base, providing and fixing 6pin 5/15amp. socket outlet and 16amp piano type switch, connections etc., as required.	5	Set
9	Earthing with copper. earth plate 600 mm X 600 mm X 3 mm thick including accessories, and providing masonry enclosure with cover plate having locking arrangement and watering pipe of 2.7 metre long etc. with charcoal/ coke and salt as required [2 for lightning conductors,4 for tower legs, 2for PDP, 2 for RF feeder cables]	10	Set
10	Providing and fixing copper strip(25mmX5mm) on surface or in recess for loop earthing as required.(for lightning conductor)	410	metre
11	Providing and laying earth connection from earth electrode with 25mmX5mm copper strip in 40 mm dia GI pipe from earth electrode including connection with brazing, excavation and refilling as required	80	metre
12	Supply and making indoor end termination with brass compression gland and copper lugs for the following size of PVC insulated and PVC sheathed / XLPE aluminum conductor cable of 1.1KV grade as required.		
	a) 4x10 sq.mm	2	Set
	b) 3x2.5 sq.mm	10	Set
13	Installation of 11 Nos. of LED AOL on various platforms on the tower. Low intensity lights- four Nos on 40m platform, two Nos on 105m	1	job

	platforms ; Medium intensity lights-two nos. each on 80m, 126m & one no. on 150 m platforms		
14	Supply and fixing of of mounting arrangement for AOLs on the platforms. The mounting arrangement shall be made out of GI pipe of 40mm dia and 1.5m height with GI base plate ,mounting plate and all accessories for fixing the stand on platforms	300	Kg

Specifications for Low Intensity LED AOL :

- a) AOL of low intensity type B must conform to the ICAO regulation with minimum Directional (radial) intensity of 32 cd, in any direction in the horizontal plane, throughout the rated operating life of AOL. The initial designed intensity should be twice the minimum ICAO intensity for a specific AOL, to allow for natural LED intensity degradation (to 50% of the initial value) over the lifetime of the unit. The test certificate from NPL giving initial intensity value in candela to greater than 64cd must be submitted by the successful bidder. The intensity rating and test certificate should be given for directional radial intensity (and not for integrated intensity i.e., total aggregated light intensity of all LEDs used all around the unit)
- b) Supplier should confirm that the product does not infringe any aspect of the Indian patents act, and should give a formal declaration to the above. The declaration should also formally promise to take over legal and financial liability from customer in case infringement of any existing patent.
- c) Material used in construction of enclosure should be LM-6 alloy (supplier should specify the composition of the metal used, supported by test certificate from a reputed laboratory) All supplementary hardware used must be rustproof.
- d) The unit should conform to IP65 ingress protection requirements (corroborated by a test certificate from a reputed laboratory) Sealing gasket must be of neoprene.
- e) The unit should be able to withstand an operating temperature range from -10 degree to 60 degree C (corroborated by a test certificate)
- f) The circuitry incorporated should be electronic in nature, with a test certificate for power consumption. Power consumption should not exceed 15watts.
- g) The AOL shall be suitable to work in operating voltage range of 170-300V AC. All low intensity AOLs should be able to withstand burn-in-ageing at 400V AC for 7 days to ensure reliability and component rating compliance.
- h) All internal wiring (where necessary) should be with teflon coated cable to enable adequate insulation characteristics.
- i) EMI/RFI protection should be provided to eliminate line harmonics, spikes and transients. The design of the unit should be such that it is not affected by high frequency RF transmission.
- j) The LEDs used should be of InP technology LEDs and not GaAs or GaP technology. The tenderer must give proof of the source of LED.
- k) LEDs used should have ultraviolet resistant encapsulation and should be capable of withstanding moisture and high ambient temperature of up to 60degree C. LED should have chip junction temperature capability of not less than 130 degree C.
- l) LEDs should be evenly distributed all around 360 degrees in horizontal plane on fire retardant printed circuit board.
- m) The lens should be toughened clear borosilicate hard glass.
- n) The unit should be able to withstand a dielectric test of 1.5KV and insulation resistance of minimum 10 MΩ.
- o) The body of the unit should be externally painted/powder coated with appropriate

- paint of aviation yellow colour.
- p) Normal continuous life should be 100,000 burning hours with light depreciation of not more than 50% at end of life.
 - q) All test report required must be submitted by the successful bidder along with the material.
 - r) Supplier should submit at least three performance reports from reputed end users of their AOL units

Specifications for Medium Intensity LED AOL :

- a) AOL of medium intensity type B must conform to the ICAO regulation with minimum Directional (radial) intensity of 1600 cd, in any direction in the horizontal plane, The initial designed intensity should be twice the minimum ICAO intensity for a specific AOL, to allow for natural LED intensity degradation (to 50% of the initial value) over the lifetime of the unit. The test certificate from NPL giving initial intensity value in candela to greater than 3200cd must be submitted by successful bidder. The intensity rating and test certificate should be given for directional radial intensity (and not for integrated intensity i.e., total aggregated light intensity of all LEDs used all around the unit)
- b) Supplier should confirm that the product does not infringe any aspect of the Indian patents act, and should give a formal declaration to the above. The declaration should also formally promise to take over legal and financial liability from customer in case infringement of any existing patent.
- c) Material used in construction of enclosure should be LM-6 alloy(supplier should specify the composition of the metal used, supported by test certificate from a reputed laboratory) All supplementary hardware used must be rustproof.
- d) The unit should conform to IP65 ingress protection requirements(corroborated by a test certificate from a reputed laboratory) Sealing gasket must be of neoprene.
- e) The unit should be able to withstand an operating temperature range from -10 degree to 60 degree C (corroborated by a test certificate)
- f) The circuitry incorporated should be electronic in nature, with a test certificate for power consumption. Power consumption should not exceed 85watts.
- g) The AOL shall be suitable to work in operating voltage range of 170-300V AC. All internal wiring (where necessary) should be with teflon coated cable to enable adequate insulation characteristics.
- h) EMI/RFI protection should be provided to eliminate line harmonics, spikes and transients. The design of the unit should be such that it is not affected by high frequency RF transmission.
- i) The LEDs used should be of InP technology LEDs and not GaAs or GaP technology. The LEDs used should have ultraviolet resistant encapsulation and should be capable of withstanding moisture and high ambient temperature of up to 60degree C. LED should have chip junction temperature capability of not less than 130 degree C.
- j) Failure of any single LED must not cause light reduction of more than 4%. Tenderer to clarify method used to achieve the same.
- k) The unit should be able to withstand a dielectric test of 1.5KV for 1 minute and insulation resistance of minimum 10 MΩ.
- l) The body of the unit should be externally painted/powder coated in appropriate paint of aviation yellow colour.
- m) Normal continuous life should be minimum 1,00,000 burning hours
- s) All test report must be submitted by the successful bidder along with the material.
- n) Supplier should submit at least three performance reports from reputed end users of their AOL units.
- o) AOL must flash synchronously together and all the flashing type must be fed from one flasher unit installed on the panel. Provision for flash rate adjustment of 20 to 60 FPM must be provided. Standby flasher unit should be provided in the panel.

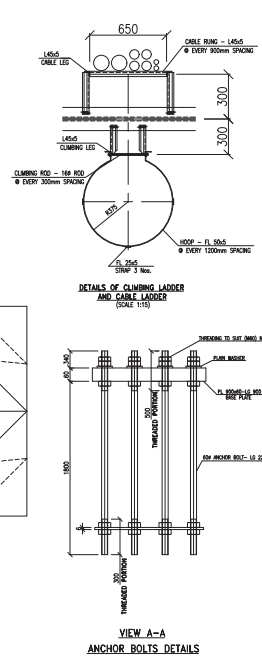
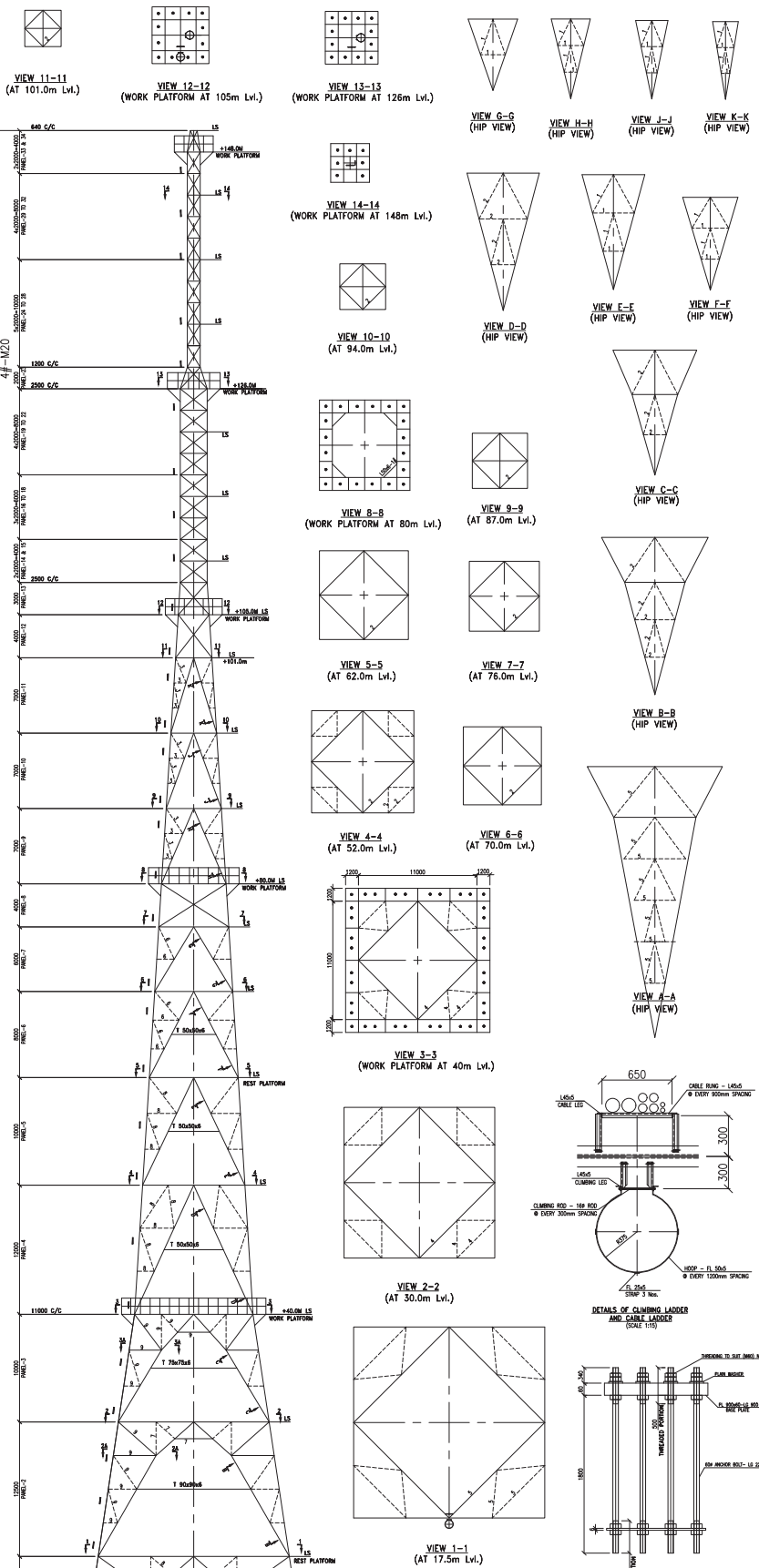
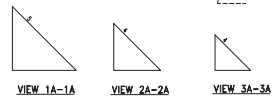
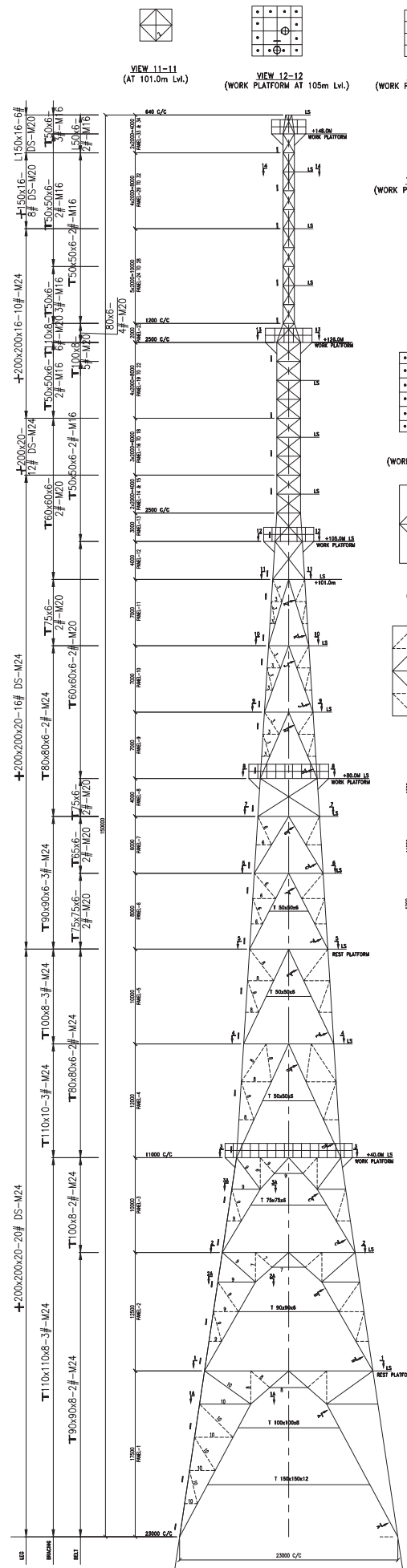

MEMBER NUMBER:

1	T 100x100
2	T 150x150
3	T 200x200
4	T 250x250
5	T 300x300
6	T 350x350
7	T 400x400
8	T 450x450
9	T 500x500
10	T 550x550
11	T 600x600
12	T 650x650
13	T 700x700
14	T 750x750
15	T 800x800
16	T 850x850
17	T 900x900
18	T 950x950
19	T 1000x1000
20	T 1050x1050
21	T 1100x1100
22	T 1150x1150
23	T 1200x1200
24	T 1250x1250
25	T 1300x1300
26	T 1350x1350
27	T 1400x1400
28	T 1450x1450
29	T 1500x1500

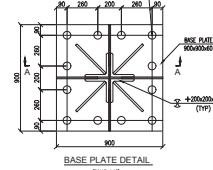

- NOTES:-
- 1) ALL DIMENSIONS ARE IN MILLIMETRES UNLESS OTHERWISE SPECIFIED
 - 2) ALL MEMBERS ARE OF STRUCTURAL STEEL CONFORMING TO IS 2062/2015 AS & B.
 - 3) STRUCTURAL STEEL SHALL BE HOT DIP GALVANIZED CONFORM TO IS 2063.
 - 4) ALL BOLTS ARE 8.8 GRADE AND CONFORM TO IS 1903.
 - 5) L1 - LADDER SUPPORT, C/C - CENTER TO CENTER.
 - 6) # - DENOTES NUMBER OF BOLTS.

CONSTRUCTION OF 150m SELF SUPPORTING TOWER
AT MAHABUBNAGAR, TELANGANA

DESIGNER	DATE	REVISION	NO.	DATE	BY	CHKD	DATE
DR	10/10/2024		1				
DR	10/10/2024		2				
DR	10/10/2024		3				
DR	10/10/2024		4				
DR	10/10/2024		5				
DR	10/10/2024		6				
DR	10/10/2024		7				
DR	10/10/2024		8				
DR	10/10/2024		9				
DR	10/10/2024		10				
DR	10/10/2024		11				
DR	10/10/2024		12				
DR	10/10/2024		13				
DR	10/10/2024		14				
DR	10/10/2024		15				
DR	10/10/2024		16				
DR	10/10/2024		17				
DR	10/10/2024		18				
DR	10/10/2024		19				
DR	10/10/2024		20				

GENERAL NOTES:-

GENERAL & MATERIAL:-

1. ALL DIMENSIONS ARE IN mm UNLESS OTHERWISE SPECIFIED (U.O.S).
2. RCC & PCC SHALL BE 'NORMAL MIX CONCRETE' OF GRADE M25 & M10 RESPECTIVELY.
3. STEEL GRADE IS FE415 U.O.S.
4. IF ANY LEVEL DIFFERENCE IN EXISTING GROUND IS FOUND, THEN SOIL EXCAVATION FOR FOUNDATION SHALL BE STARTED WITH REFERENCE TO THE LOWER LEVEL AND THE SOIL SHALL BE BACK FILLED AND COMPACTED UPTO TH ETOP MOST LEVEL OF NATURAL GROUND LEVEL TO AVOID SOIL EROSION.

TECHNICAL SPECS:-

5. MINIMUM COVER TO THE MAIN REINFORCEMENT IS GIVEN BELOW UNLESS OTHERWISE SPECIFIED FOR PEDESTAL 100mm
6. THE LAP LENGTH/DEVELOPMENT LENGTH OF BARS SHOULD BE 50 ϕ AND STAGGERED. HOWEVER, IT IS PREFERABLE TO WELD BARS IN CHIMNEY/COLUMN. WELD SHALL BE CONTINUOUS FOR A MINIMUM LENGTH OF 450mm PER EACH BAR WITH 10mm THICK WELD ON BOTH SIDES.
7. NO HONEYCOMB SHALL BE PERMITTED WHILE CONCRETING.
8. NO CONSTRUCTION JOINT SHALL BE ALLOWED.
9. STRIPPING OF FORM WORK SHALL BE CARRIED OUT AFTER A MINIMUM PERIOD OF 24 HRS AFTER CONCRETING.

EXCAVATION & BACKFILLING:-

10. SAND BEDDING/STONE BEDDING SHALL BE PROVIDED IN FOUNDATIONS OF MARSHY AND WET BLACK COTTON FOUNDATIONS.
11. IN CASE NO GROUND WATER, ALL FOUNDATION PITS SHALL BE SOAKED WITH WATER FOR 24 HOURS AND COMPACT WELL BEFORE FOUNDATIONS ARE LAID.
12. LOOSE POCKETS PF SOIL, (IF ANY) IN FOUNDATIONS SHALL BE COMPLETELY REMOVED & FILLED WITH P.C.C & COMPACTED WELL BEFORE FOUNDATIONS ARE LAID.
13. ALL BACK FILLING OF FOUNDATION SHOULD BE DONE WITH WELL COMPACTED MURRAM SOIL.
14. THE BACK FILLING MATERIALS SHOULD BE CLEAN & FREE FROM ORGANIC OR OTHER FOREIGN MATERIALS.
15. SOIL BACK FILL SHALL BE DONE IN LAYERS OF APPROX 150-200mm, EACH LAYERS SHALL BE DENSELY COMPACTED BY SPRINKLING MIN.QUANTITY OF WATER AS NECESSARY FOR PROPER COMPACTION.
16. CASE SHALL BE TAKEN THAT THE BACK FILLING IS STARTED FROM THE CENTRE TOWARDS THE OUTER ENDS.
17. AFTER BACK FILLING 50mm HIGH EARTHEN EMBANKMENT(BUND) WILL BE MADE ALONG THE SIDES OF EXCAVATED PITS AND SUFFICIENT WATER WILL BE Poured OVER THE BACK FILLED EARTH FOR ATLEAST 24 HRS.

CURING:-

18. CURING OF FOUNDATION SHALL BE CARRIED OUT OVER A MIN. PERIOD OF 7 DAYS IN THE FOLLOWING MANNER.
 - a) BASE RAFT, BEAM SHALL BE KEPT CONTINUOUSLY IN DAMP OR WET CONDITION BY PONDING OR BY COVERING WITH SACKING FOR A MINIMUM PERIOD OF 2 DAYS AFTER FINAL SETTING TIME OF CONCRETE (12 HRS approx)
 - b) BACK FILLING SHALL START AFTER 72 HRS OF CONCRETING.
 - c) AFTER COMPLETION OF BACK FILLING THE SOIL SHALL BE KEPT MOIST/WET/DAMP CONDITION UNTIL 7 DAYS FROM CONCRETING.
19. TOWER ERECTION SHALL START AFTER 7 DAYS OF CONCRETING AND OR MIN. 3 DAYS AFTER ANCHOR BOLT SETTING.

TEMPLATE ASSEMBLY/GROUTING:-

20. VERIFY BOLT, NUT SIZE AND LENGTH AS PER TEMPLATE/BASE ASSEMBLY DRAWING.
21. CHECK THE INTEGRITY OF BOLT AND NUT BEFORE EXECUTION AT SITE. IF ANY PLAY FOUND, CONSULT SITE ENGINEER/CONSULTANT.
22. GROUTING UNDER BASE PLATE HAS TO BE DONE WITH C25 GRADE CONCRETE.
23. SURFACE OF THE GROUT SHALL BE SMOOTHLY FINISH WITH CW(1:5)
24. AS MUCH AS POSSIBLE THICKNESS OF THE GROUT SHOULD BE LESS.

NOTES ON GENERIC FOUNDATION DRAWING:-

1. ALL DIMENSIONS ARE IN mm UNLESS OTHERWISE SPECIFIED.
2. THIS IS A GENERIC FOUNDATION DRAWING.
3. THE FOUNDATION DESIGN IS AS PER INDIAN DESIGN STANDARDS
4. AN OVERLOAD FACTOR OF 2 IS CONSIDERED FOR ANCHOR DESIGN AND 1.5 IS CONSIDERED FOR REINFORCEMENT DESIGN
5. THE FOLLOWING THE ASSUMED PARAMETERS CONSIDERED DURING THE FOUNDATION DESIGN
SAFE BEARING CAPACITY = 589 kPa(HARD ROCK)
GROUND WATER TABLE = NIL
6. BEFORE COMMENCEMENT OF CONSTRUCTION WORK USING THESE DESIGNS, THE OWNER/CLIENT/CONTRACTOR SHALL CARRY OUT DETAILED SOIL INVESTIGATION FOR EVERY SITE. FURTHER, THE SOIL INVESTIGATION REPORT SHALL BE REVIEWED BY A CONSULTANT AND CERTIFICATION SHALL BE OBTAINED TO ENSURE THE CONFORMITY BETWEEN ASSUMED PARAMETERS AND SOIL REPORT VALUES BEFORE START OF CONSTRUCTION.
7. THE FOUNDATION DESIGN IS APPLICABLE ONLY IF ASSUMED SBC IS AVAILABLE AT OR WITHIN THE ASSUMED DEPTH FROM F.G.L IN BOTH CASES.
8. THIS FOUNDATION DESIGN SHALL NOT BE USED IN CASE ORGANIC SILT/ORGANIC CLAY OR PEAT LAYERS ARE FOUND AT ANY DEPTH DURING SOIL INVESTIGATION.
9. THIS FOUNDATION DESIGN SHALL NOT BE ADOPTED AT SITES WHERE GROUND IMPROVEMENTS ARE REQUIRED.

REV.	DATE	DESCRIPTION	BY	CHKD.	APPD.
M/s.PRASAR BHARATI(INDIA PUBLIC SERVICE BROADCAST) CIVIL CONSTRUCTION IN ALL INDIA RADIO & TV AT MAHABUBNAGAR-TELANGANA					
TITLE:- ROCK ANCHOR FOUNDATION DRAWING FOR 150m HIGH SQUARE TOWER SBC: 589kPa(HARD ROCK)					
DESIGN	IIT	SCALE	N.T.S	DRAWING No:	REV.
DRAWN	G.T.K	DRAWN DATE	27.12.16	JTT/IIT-M/DEC/16/05/DD/272/FDN	0
CHECKED	G.T.K	CHECK DATE	27.12.16		

BAR BENDING SCHEDULE

ITEM NO	DIAMETER	SHAPE	LENGTH	Nos.	Wt/m	TOTAL WT	REMARKS
1	10		19380	20x2	0.62	480	LATERAL TIES NORTH SIDE
2	42		6225	36x2	10.89	4881	ANCHOR RODS NORTH SIDE
3	10		23400	39x2	0.62	1132	LATERAL TIES SOUTH SIDE
4	50		9825	36x2	15.43	10916	ANCHOR RODS SOUTH SIDE
TOTAL						17409 kg	
						871 kg	5% EXTRA

BILL OF QUANTITIES:-
 CONCRETE QUANTITY(M25) = 730 Cu.m
 CEMENT GROUTING (M25) = 2.9 Cu.m
 WEIGHT OF STEEL(FE415) = 18280 kg

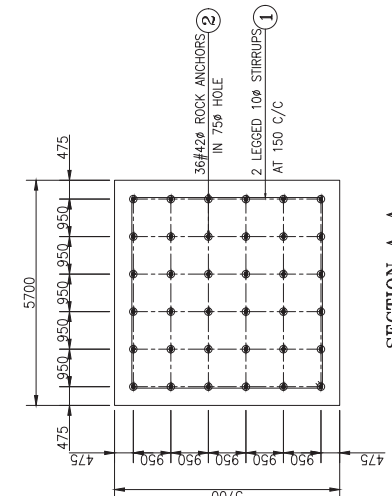

SECTION A-A
PEDESTAL DETAILS-NORTH SIDE

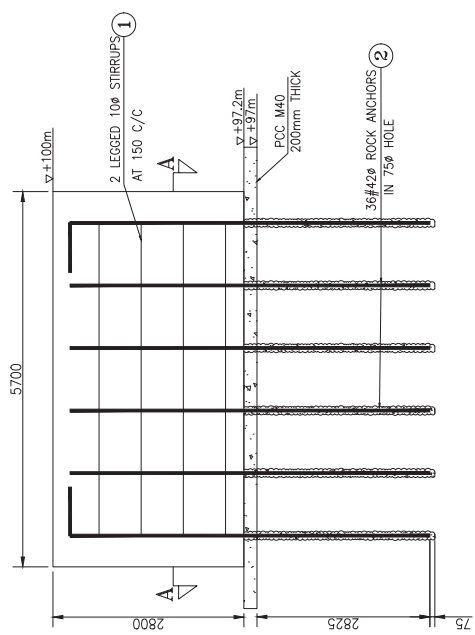

FOUNDATION DETAILS-NORTH SIDE

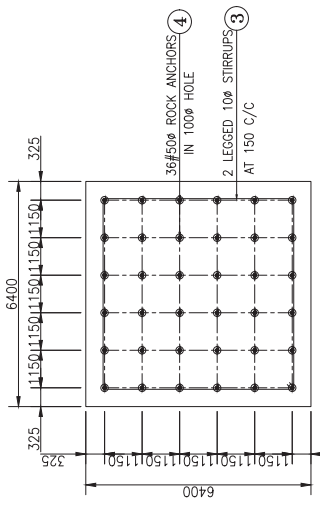

SECTION B-B
PEDESTAL DETAILS-SOUTH SIDE

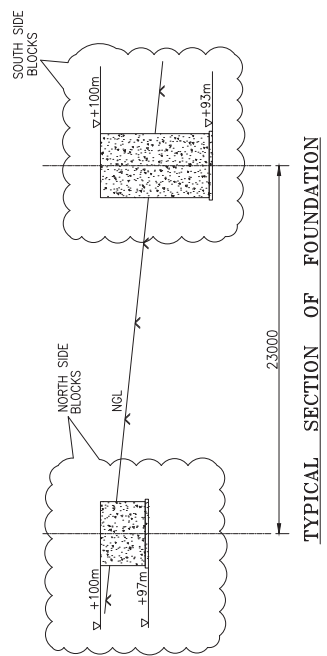

TYPICAL SECTION OF FOUNDATION

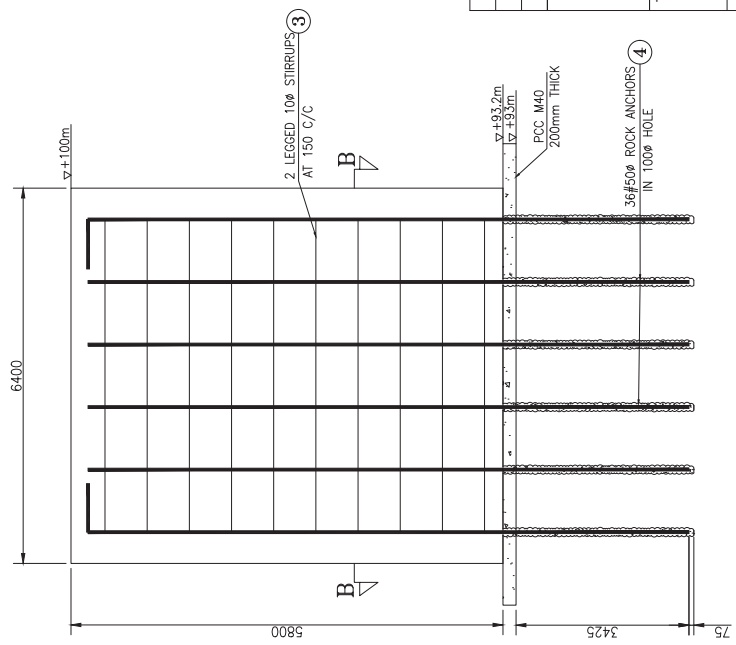

FOUNDATION DETAILS-SOUTH SIDE

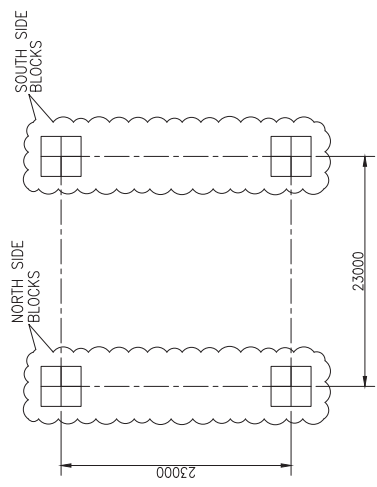

TYPICAL PLAN OF FOUNDATION

REV.	DATE	DESCRIPTION	BY	CHKD.	APPD.

M/s.PRASAR BHARATI(INDIA PUBLIC SERVICE BROADCAST) CIVIL CONSTRUCTION IN ALL INDIA RADIO & TV AT MAHABUBNAGAR-TELANGANA

TITLE:-
ROCK ANCHOR FOUNDATION DRAWING FOR 150m HIGH SQUARE TOWER
SBC: 589kPa(HARD ROCK)

DESIGN	IT	SCALE	N.T.S	DRAWING No.:
DRAWN	G.T.K	DRAWN DATE	27.12.16	JTT/IT-M/DEC/16/05/DD/272/IDN
CHECKED	G.T.K	CHECK DATE	27.12.16	

**DOORDHARSHAN
TV TRANSMITTER**
MAIN FEEDER SUPPLY ASSEMBLY

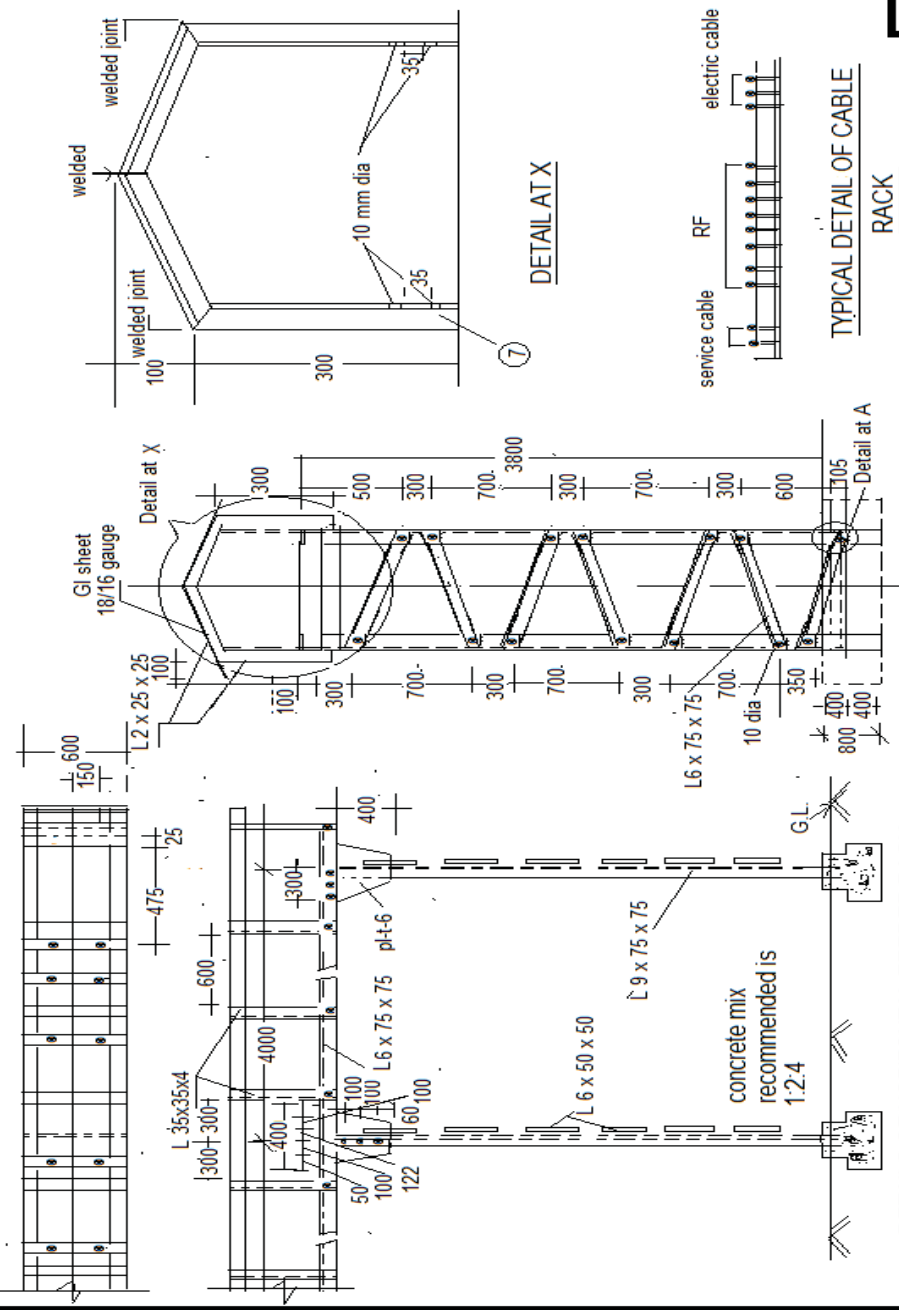

DETAILS OF HORIZONTAL FEEDER RACK

ELEVATION AT AA

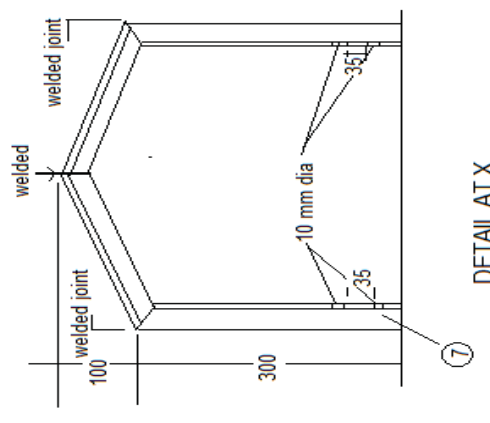

DETAIL AT X

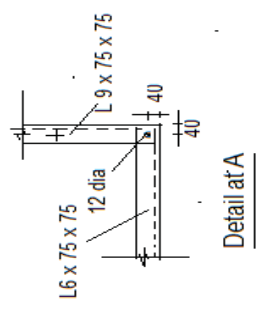

Detail at A

Provision for following cable feeder cable to be made

- 1) 2 nos for 115 dia
- 2) 2 nos for 80 dia
- 3) 2 nos for 40 dia

along with service and electrical cable

Dimensions shall not be scaled off.

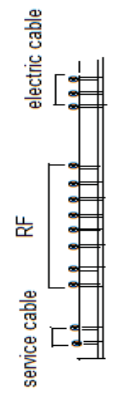

TYPICAL DETAIL OF CABLE RACK

Extract copy of Drawing No. TVT-5094/R3 of DG,
Doordharshan, New Delhi /Main feeder supply assembly/
TV transmitter.

(SUGGESTIVE DRAWING)

PLATE EARTHING

NOTES:-

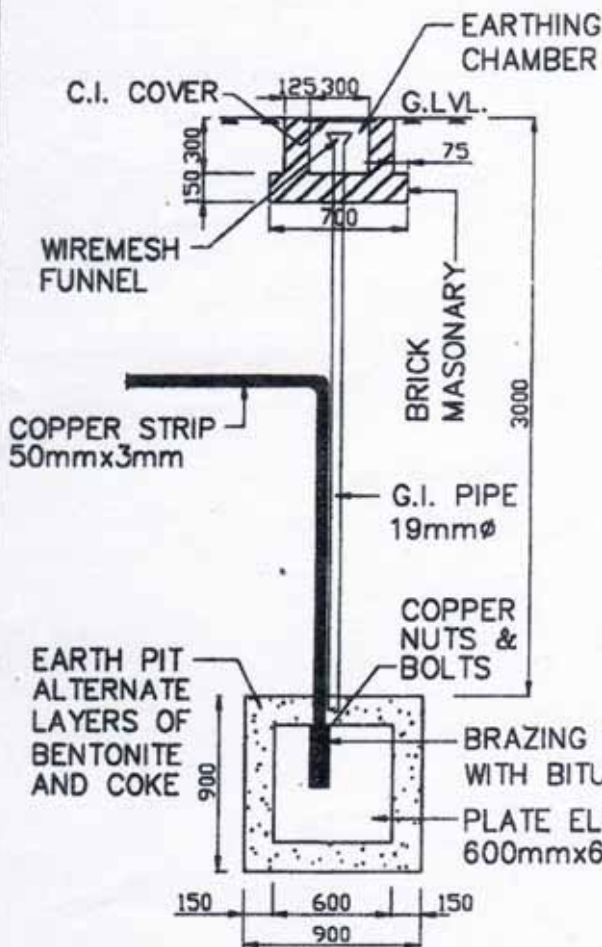
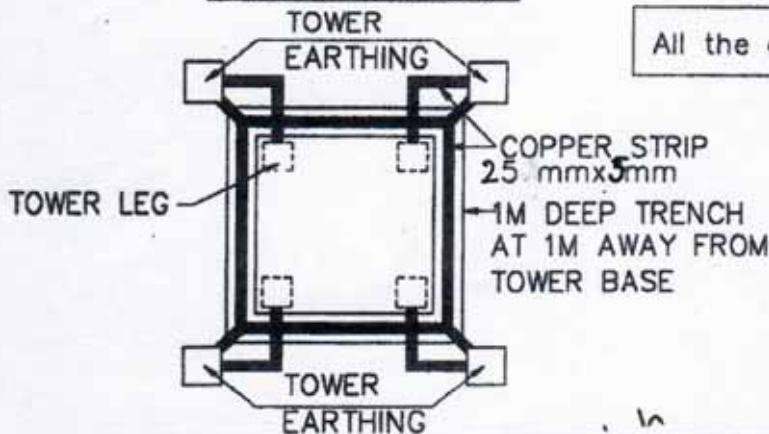

Plate Earth: Pit size of 900x900x3900 mm is excavated & copper plate of size 600x600x3.0 mm is placed vertically in the excavated pit. The plate shall be connected to copper strip of 50x3mm. The bolt, nuts, check nuts & washers shall be of copper. The pit is filled with alternate layers of coke & bentonite up to a depth of 900mm & remaining portion filled with loose soil without stones. The masonry chamber at ground level of size 700x700x150mm with a hole in the middle to pass the G.I. pipe of 19mm dia with a provision for funnel & provided with C.I. frame & cover with locking arrangements. The funnel shall be fixed with wiremesh. The main hole cover shall be painted & marked with resistance of the earth.

Ring Earth: The trench all-around at 1m away from the tower base shall be excavated to a depth of 1m. 25x5mm copper strip placed at the bottom of the trench. All the copper earth electrodes shall be interconnected as shown in the drawing.

RING EARTHING



All the dimensions are in millimeters.